

## Harvatek Surface Mount CHIP LED Data Sheet HT-C3501BPU Standard Datasheet

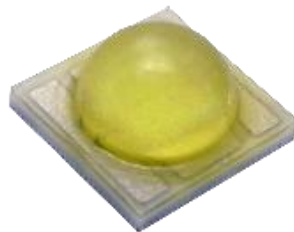

Official Product	HT Part No. HT-C3501BPU	Your Part No.		Data Sheet No.
Tentative Product	*****	*****		Standard
Specifications are subject to changes for improvement without advance notice. Proprietary data, drawings, and company confidential all rights reserved.		July 08, 2011	Version of V1.2	Page 1/35

## CONTENTS

Introduction.....	4
Product Specification.....	5
Label Spec.....	5
Description of Model No. and Lot No.....	6
Product Feature.....	6
Application.....	7
Product Out Line Dimension.....	7
Electro-Optical.....	8
Absolute Maximum Rating.....	8
Electro-Optical Characteristics.....	8
Luminous Flux Rank.....	8
Electrical Rank.....	9
Color Temperature Coordinates.....	9
Correlated Color Temperature Rank.....	10
Bin and Order Code Format.....	12
Standard Order Codes and Bins (HT-C3501BPU Warm white).....	14
Color Temperature Coordinates.....	15
Correlated Color Temperature Rank.....	15
Luminous Flux Rank.....	16
Electrical Rank.....	16
Standard Order Codes and Bins (HT-C3501BPU Neutral white).....	17
Color Temperature Coordinates.....	18
Correlated Color Temperature Rank.....	18
Luminous Flux Rank.....	19
Electrical Rank.....	19
Standard Order Codes and Bins (HT-C3501BPU Pure white).....	20
Color Temperature Coordinates.....	21
Correlated Color Temperature Rank.....	21
Luminous Flux Rank.....	22
Electrical Rank.....	22
Standard Order Codes and Bins (HT-C3501BPU Cold white).....	23
Color Temperature Coordinates.....	23
Correlated Color Temperature Rank.....	24
Luminous Flux Rank.....	24
Electrical Rank.....	24
Color Temperature Coordinates.....	25
Characteristics Curve.....	26

Official Product	HT Part No. HT-C3501BPU	Your Part No.		Data Sheet No.
Tentative Product	*****	*****		Standard
Specifications are subject to changes for improvement without advance notice. Proprietary data, drawings, and company confidential all rights reserved.		July 08, 2011	Version of V1.2	Page 2/35

Tape & Packing.....30  
     Tape Dimension.....30  
     Reel Dimension.....30  
 Packing.....31  
     Dry Pack.....31  
     Storage.....31  
 Precautions.....32  
 Soldering Pattern.....33  
 Reflow Soldering.....33  
 Cleaning.....34  
 Cautions of Pick and Place.....34  
 LEDs and Eye Safety.....34

Official Product	HT Part No. HT-C3501BPU	Your Part No.		Data Sheet No.
Tentative Product	*****	*****		Standard
Specifications are subject to changes for improvement without advance notice. Proprietary data, drawings, and company confidential all rights reserved.		July 08, 2011	Version of V1.2	Page 3/35

## Introduction

- The information contained herein is presented only as a guide for the applications of our products. No responsibility is assumed by HARVATEK for any infringements of intellectual property or other rights of the third parties which may result from it use.
- HARVATEK is continually making an effort to improve the quality of its products. Nevertheless, semiconductor devices in general can malfunction or fail due to their inherent electrical sensitivity and vulnerability to physical stress. It is the responsibility of the buyer, when utilizing HARVATEK products, to comply with the standards of safety in making a safe design for the entire system, and to avoid situations in which a malfunction or failure of such HARVATEK products cause loss of human life, bodily injury or damage to property.
- The HARVATEK products listed in this document are intended for usage in general electronics (computer, personal equipment, office equipment, industrial robotics, domestic, etc...) These products are neither intended nor warranted for usage in equipment that requires extraordinarily high quality and/or reliability or a malfunction or failure of which may cause loss of human life or bodily injury.
- In developing your designs, please ensure that HARVATEK products are used within specified operating ranges as set forth in the most recent HARVATEK products specifications.
- Also, please keep in mind of the precautions listed in this document.

Official Product	HT Part No. HT-C3501BPU	Your Part No.		Data Sheet No.
Tentative Product	*****	*****		Standard
Specifications are subject to changes for improvement without advance notice. Proprietary data, drawings, and company confidential all rights reserved.		July 08, 2011	Version of V1.2	Page 4/35

## Product Specification

	Specification	Material	Quantity
Total Flux	Typical 108 lm @ 350mA/ Ta= 25°C		
Correlated Color Temperature	2550K~10000K @ 350mA/ Ta=25°C		
V <sub>F</sub>	3.03-3.99V @ 350mA/ Ta=25°C		
I <sub>R</sub>	HT standard		
Resin	Yellow	Silicone resin	
Carrier tape	EIA 481-1A specs	Conductive black tape	200pcs per reel
Reel	EIA 481-1A specs	Conductive black	
Label	HT standard	Paper	
Packing bag	HT standard	Aluminum laminated bag/ no-zipper	One reel per bag
Carton	HT standard	Paper	Non-specified

Others:

### ATTENTION: Electric Static Discharge (ESD) protection



The symbol shown on the page herein to introduce 'Electro-Optical Characteristics'. ESD protection for GaP and AlGaAs based chips is still necessary even though they are safe in low static-electric discharge. Parts built with AlInGaP, GaN, or/and InGaN based chips are

**STATIC SENSITIVE devices.** ESD protection has to be considered and taken in the initial design stage. If manual work/process is needed, please ensure the device is well protected from ESD during all the process.

### Compliance and Certification

RoHS compliant and ISO9002, QS9000 and ISO14001 certified.



## Label spec.

<b>HARVATEK</b> <small>RE890917-CT081008-00002332</small>		DATE: dd/mm/yyyy 	
CUSTOMER P/N: 			
HARVATEK P/N: 		QTY: 	PCS
LOT NO: 		QC: 	
IV: 	CR: 	VF: 	

Official Product	HT Part No. HT-C3501BPU	Your Part No.	Data Sheet No.
Tentative Product	*****	*****	Standard
Specifications are subject to changes for improvement without advance notice. Proprietary data, drawings, and company confidential all rights reserved.		July 08, 2011	Version of V1.2
			Page 5/35

## Description of Model No. and Lot No.

### Model No.

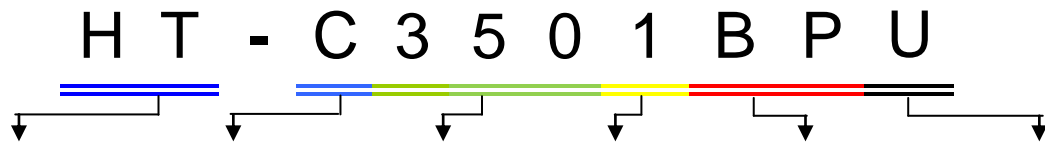

Company	Product Name	Package	Dice	Emitter Color	Current code
HT: For Harvatek	C: Ceramic substrate	Outline dimension	1: Single 2: Twin	BP: White	U: 350mA

### Lot No.

1	2	3	4	5	6	7	8	9	10
<b>E</b>	<b>1</b>	<b>A</b>	<b>1</b>	<b>A</b>	<b>2</b>	<b>2</b>	<b>L</b>	<b>1</b>	<b>2</b>
Code 1 2		Code 3	Code 4	Code 5	Code 6	Code 7	Code 8	Code 9	Code 10
		Mfg. Year	Mfg. Month	Mfg. Date	Consecutive number		Special code		
Internal Tracing Code		2010-A 2011-B 2012-C 2013-D . .	1:Jan. 2:Feb. .... A:Oct. B:Nov. C:Dec.	1:A 2:B 3:C ... 26:Z 27:7 28:8 29:9 30:3 31:4	01~ZZ		000~ZZZ		

### Product Feature

- small package with high efficiency
- Wide view angle
- Easy to fixed
- No UV
- Long operating time (Up to 50,000hrs)
- point source with color uniformity
- Lower forward voltage operated
- More energy efficient than incandescent and most halogen lamps
- ESD with 1KV
- Instant light (less than 100nS)

Official Product	HT Part No. HT-C3501BPU	Your Part No.		Data Sheet No.
Tentative Product	*****	*****		Standard
Specifications are subject to changes for improvement without advance notice. Proprietary data, drawings, and company confidential all rights reserved.		July 08, 2011	Version of V1.2	Page 6/35

## Application

- Reading lights (car, bus, aircraft)
  - Portable (flashlight, bicycle)
  - Task lighting
  - Garden lighting
  - Rail lighting
- Wayside lighting
  - LCD Backlights
  - Light Guides
  - Traffic signaling
  - Architectural lighting

## Product Out Line Dimension

Tolerance: +/-0.1

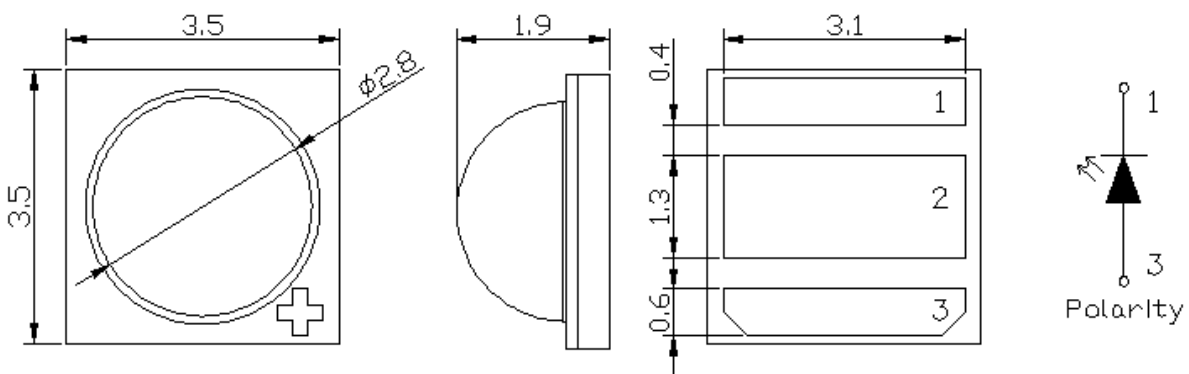

Unit: mm

Official Product	HT Part No. HT-C3501BPU	Your Part No.		Data Sheet No.
Tentative Product	*****	*****		Standard
Specifications are subject to changes for improvement without advance notice. Proprietary data, drawings, and company confidential all rights reserved.		July 08, 2011	Version of V1.2	Page 7/35

## Electro-Optical

### Absolute Maximum Ratings

(T<sub>a</sub> =25°C)

Parameter	Rating	Unit	Conditions
DC Forward Current <sup>*1</sup>	350	mA	-
Peak Pulsed Forward Current <sup>*2</sup>	1000	mA	-
Reverse Voltage	5	V	-
LED junction Temperature	120	°C	-
Operating Temperature	-30~+85	°C	-
Storage Temperature	-40~+120	°C	-
Soldering Temperature	260	°C	For 5 sec. Max.

\*1: Proper current derating must be observed to maintain junction temperature below the maximum

\*2:tp≤10μs, Duty cycle=0.01

### Electro-Optical Characteristics

(T<sub>a</sub> =25°C)

Parameter	Symbol	Min.	TYP.	Max.	Unit
Viewing angle	2θ ½	115	-	130	Deg.
Forward Voltage (I <sub>F</sub> =350mA)	V <sub>F</sub>	3.03	-	3.99	V
Luminous Flux	Flux	-	108	-	lm
Correlated Color Temperature	CCT	2550	-	10000	K
Temperature Coefficient of Forward Voltage	ΔV <sub>F</sub> /ΔT	-	2	-	mV/°C
Thermal Resistance Junction to Board (I <sub>F</sub> =350mA)	Rθ <sub>J-B</sub>	-	9	-	°C/W
CRI			70		

### Luminous Flux Rank

Rank Code	Symbol	Condition	Min.	Typ.	Max.	Unit
Full	ΦV	I <sub>F</sub> =350mA	67.2	-	147.2	lm
PT1			67.2	-	76.6	
PT2			76.6	-	87.4	
PU1			87.4	-	99.6	
PU2			99.6	-	113.6	
PV1			113.6	-	129.5	
PV2			129.5	-	147.2	

Note: It maintains a tolerance of ±10% on flux

Official Product	HT Part No. HT-C3501BPU	Your Part No.	Data Sheet No.
Tentative Product	*****	*****	Standard
Specifications are subject to changes for improvement without advance notice. Proprietary data, drawings, and company confidential all rights reserved.		July 08, 2011	Version of V1.2
			Page 8/35

## Electrical Rank

Rank Code	Symbol	Condition	Min.	Typ.	Max.	Unit
Full	V <sub>F</sub>	I <sub>F</sub> =350mA	3.03	-	3.99	V
P05			3.03	-	3.27	
P06			3.27	-	3.51	
P07			3.51	-	3.75	
P08			3.75	-	3.99	

Note: It maintains a tolerance of ±0.1V on forward voltage measurements

## Color Temperature Coordinates

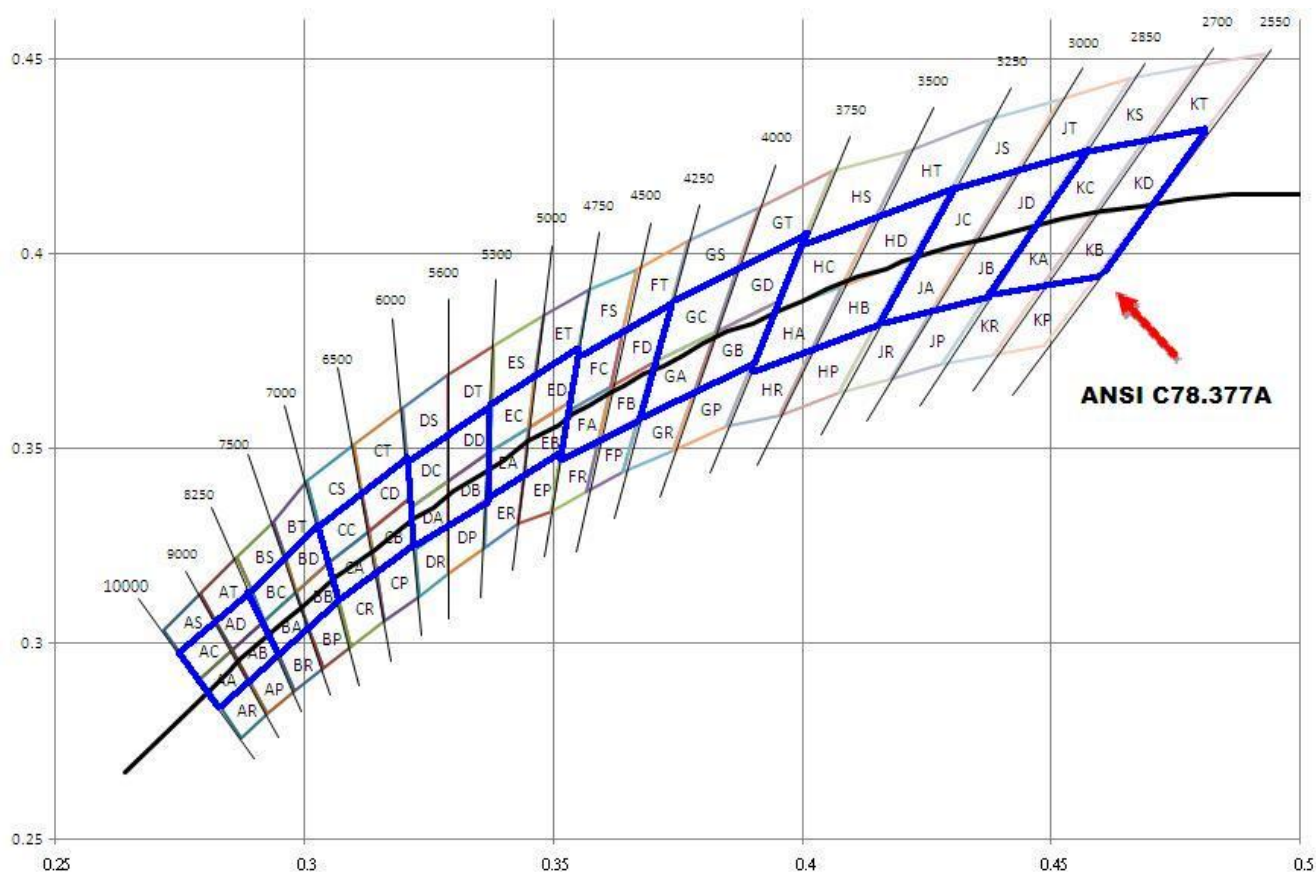

Official Product	HT Part No. HT-C3501BPU	Your Part No.	Data Sheet No.
Tentative Product	*****	*****	Standard
Specifications are subject to changes for improvement without advance notice. Proprietary data, drawings, and company confidential all rights reserved.		July 08, 2011	Version of V1.2
			Page 9/35

## Correlated Color Temperature Rank

Condition	Color	Bin Code	Min.	Typ.	Max.	Unit
I <sub>F</sub> =350mA	Warm White	KD	2550	-	2700	K
		KB	2550	-	2700	
		KC	2700	-	2850	
		KA	2700	-	2850	
		JD	2850	-	3000	
		JB	2850	-	3000	
		JC	3000	-	3250	
		JA	3000	-	3250	
		HD	3250	-	3500	
		HB	3250	-	3500	
		HC	3500	-	3750	
		HA	3500	-	3750	
	Neutral White	GD	3750	-	4000	
		GB	3750	-	4000	
		GC	4000	-	4250	
		GA	4000	-	4250	
		FD	4250	-	4500	
		FB	4250	-	4500	
		FC	4500	-	4750	
		FA	4500	-	4750	
		ED	4750	-	5000	
		EB	4750	-	5000	
		EC	5000	-	5300	
		EA	5000	-	5300	
	Pure White	DD	5300	-	5600	
		DB	5300	-	5600	
		DC	5600	-	6000	
		DA	5600	-	6000	
		CD	6000	-	6500	
		CB	6000	-	6500	
		CC	6500	-	7000	
		CA	6500	-	7000	
	Cold white	BD	7000	-	7500	

Official Product	HT Part No. HT-C3501BPU	Your Part No.		Data Sheet No.
Tentative Product	*****	*****		Standard
Specifications are subject to changes for improvement without advance notice. Proprietary data, drawings, and company confidential all rights reserved.		July 08, 2011	Version of V1.2	Page 10/35

		BB	7000	-	7500
		BC	7500	-	8250
		BA	7500	-	8250
		AD	8250	-	9000
		AB	8250	-	9000
		AC	9000	-	10000
		AA	9000	-	10000

Official Product	HT Part No. HT-C3501BPU	Your Part No.		Data Sheet No.
Tentative Product	*****	*****		Standard
Specifications are subject to changes for improvement without advance notice. Proprietary data, drawings, and company confidential all rights reserved.		July 08, 2011	Version of V1.2	Page 11/35

## BIN AND ORDER CODE FORMAT

Bin codes and order codes are configured in the following manner:

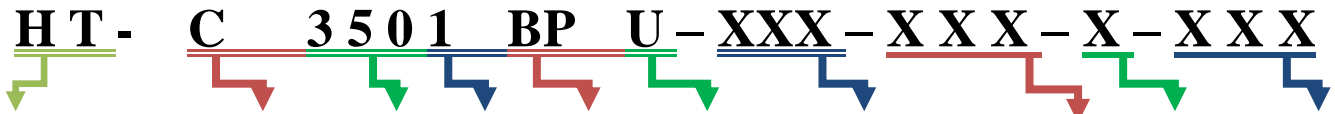

Company	Product	Package	Dice	Color	Current	CCT	LM	VF	CRI
Harvatek	Ceramic Substrate	Outline Dimension	1: Single	BP: White	U: 350mA	<b>WW:</b> Warm White (Ka Kb Kc Kd Ja Jb Jc Jd Ha Hb Hc Hd) <b>WJ:</b> Warm White (Ja Jb Jc Jd) <b>WH:</b> Warm White (Ha Hb Hc Hd) <b>NW:</b> Neutral White (Ga Gb Gc Gd Ea Eb Ec Ed Fa Fb Fc Fd) <b>NGF:</b> Neutral White (Ga Gc Fb Fd) <b>NG:</b> Neutral White (Ga Gb GC GD) <b>NEF:</b> Neutral White (Ea Eb Ec Ed Fa Fb Fc Fd) <b>NE:</b> Neutral White (Ea Eb Ec Ed)	PT1 PT2 PU1 PU2 PV1 PV2	F: FULL (P05- P08)	CR1: Typ. 70  CR2: Typ. 75

Official Product	HT Part No. HT-C3501BPU	Your Part No.	Data Sheet No.
Tentative Product	*****	*****	Standard
Specifications are subject to changes for improvement without advance notice. Proprietary data, drawings, and company confidential all rights reserved.		July 08, 2011	Version of V1.2
			Page 12/35

						<p><b>NE:</b>          Neutral White          (Fa Fb Fc Fd)</p> <p><b>PW:</b>          Pure white          (Ca Cb Cc Cd          Da Db Dc Dd)</p> <p><b>PDE:</b>          Pure White          (Da Db Dc Dd          Ea Ec)</p> <p><b>PD:</b>          Pure White          (Da Db          Dc Dd)</p> <p><b>CW:</b>          Cold White          (Aa Ab Ac Ad          Ba Bb Bc Bd)</p>			
--	--	--	--	--	--	--	--	--	--

Official Product	HT Part No. HT-C3501BPU	Your Part No.		Data Sheet No.
Tentative Product	*****	*****		Standard
Specifications are subject to changes for improvement without advance notice. Proprietary data, drawings, and company confidential all rights reserved.		July 08, 2011	Version of V1.2	Page 13/35

## Standard Order Codes and Bins (HT-C3501BPU Warm White)

The following tables of order codes list Correlated Color Temperature, Luminous Flux, Forward Voltage and CRI regions for the various categories of HT-C3501BPU. For other combinations, contact Harvatek or an authorized distributor.

HT-C3501BPU Standard Order Codes - Warm White					
Condition	Correlated Color Temperature	Luminous Flux	Forward Voltage	CRI	Order Code
I <sub>F</sub> =350mA	Ka Kb Kc Kd Ja Jb Jc Jd Ha Hb Hc Hd (2550-3750°K)	PT1 PT2	Full P05 P06 P07 P08	75	HT-C3501BPU-WW-PT1-F-CR2
	Ja Jb Jc Jd (2850-3250°K)	PT1 PT2	Full P05 P06 P07 P08	75	HT-C3501BPU-WJ-PT1-F-CR2
	Ha Hb Hc Hd (3250-3750°K)	PT1 PT2	Full P05 P06 P07 P08	75	HT-C3501BPU-WH-PT1-F-CR2

Official Product	HT Part No. HT-C3501BPU	Your Part No.		Data Sheet No.
Tentative Product	*****	*****		Standard
Specifications are subject to changes for improvement without advance notice. Proprietary data, drawings, and company confidential all rights reserved.		July 08, 2011	Version of V1.2	Page 14/35

## Color Temperature Coordinates

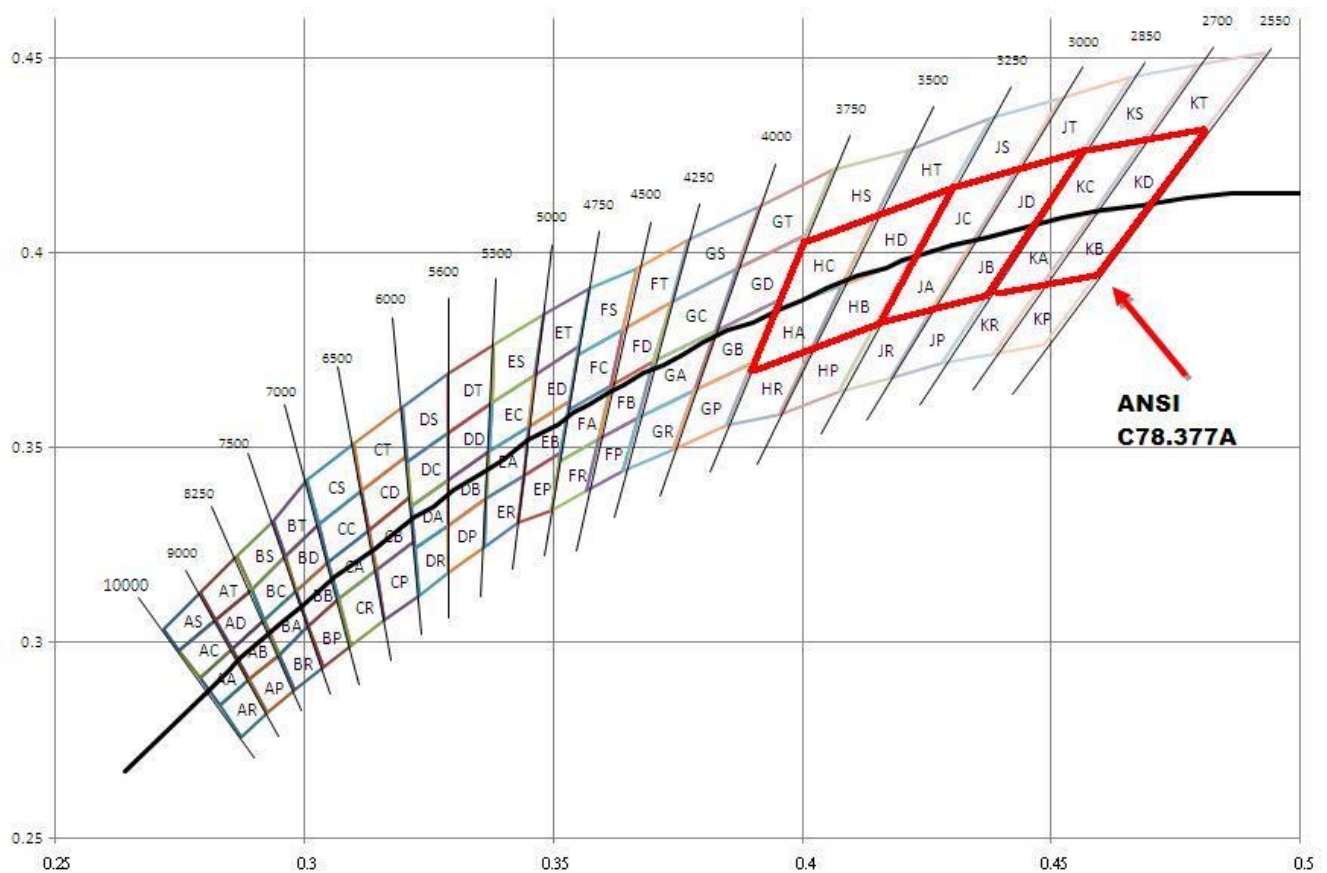

## Correlated Color Temperature Rank

Condition	Color	Bin Code	Min.	Typ.	Max.	Unit
I <sub>F</sub> =350mA	Warm White	KD	2550	-	2700	K
		KB	2550	-	2700	
		KC	2700	-	2850	
		KA	2700	-	2850	
		JD	2850	-	3000	
		JB	2850	-	3000	
		JC	3000	-	3250	
		JA	3000	-	3250	
		HD	3250	-	3500	
		HB	3250	-	3500	
		HC	3500	-	3750	
		HA	3500	-	3750	

Official Product	HT Part No. HT-C3501BPU	Your Part No.	Data Sheet No.
Tentative Product	*****	*****	Standard
Specifications are subject to changes for improvement without advance notice. Proprietary data, drawings, and company confidential all rights reserved.		July 08, 2011	Version of V1.2
			Page 15/35

### Luminous Flux Rank

Rank Code	Symbol	Condition	Min.	Typ.	Max.	Unit
Full	ΦV	I <sub>F</sub> =350mA	67.2	-	87.4	lm
PT1			67.2	-	76.6	
PT2			76.6	-	87.4	

Note: It maintains a tolerance of ±10% on flux

### Electrical Rank

Rank Code	Symbol	Condition	Min.	Typ.	Max.	Unit
Full	V <sub>F</sub>	I <sub>F</sub> =350mA	3.03	-	3.99	V
P05			3.03	-	3.27	
P06			3.27	-	3.51	
P07			3.51	-	3.75	
P08			3.75	-	3.99	

Note: It maintains a tolerance of ±0.1V on forward voltage measurements

Official Product	HT Part No. HT-C3501BPU	Your Part No.		Data Sheet No.
Tentative Product	*****	*****		Standard
Specifications are subject to changes for improvement without advance notice. Proprietary data, drawings, and company confidential all rights reserved.		July 08, 2011	Version of V1.2	Page 16/35

## Standard Order Codes and Bins (HT-C3501BPU Neutral White)

The following tables of order codes list Correlated Color Temperature, Luminous Flux, Forward Voltage and CRI regions for the various categories of HT-C3501BPU. For other combinations, contact Harvatek or an authorized distributor.

HT-C3501BPU Standard Order Codes - Neutral White					
Condition	Correlated Color Temperature	Luminous Flux	Forward Voltage	CRI	Order Code
I <sub>F</sub> =350mA	Ga Gb Gc Gd Ea Eb Ec Ed Fa Fb Fc Fd (3750-5300°K)	PT2 PU1 PU2	Full P05 P06 P07 P08	70	HT-C3501BPU-NW-PT2-F-CR1
	Ga Gc FB FD (4000-4500°K)	PT2 PU1 PU2	Full P05 P06 P07 P08	75	HT-C3501BPU-NGF-PT2-F-CR2
	Ga Gb Gc Gd (3750-4250°K)	PT2 PU1 PU2	Full P05 P06 P07 P08	75	HT-C3501BPU-NG-PT2-F-CR2
	Ea Eb Ec Ed Fa Fb Fc Fd (4250-5300°K)	PT2 PU1 PU2	Full P05 P06 P07 P08	70	HT-C3501BPU-NEF-PT2-F-CR1
	Ea Eb Ec Ed (4750-5500°K)	PT2 PU1 PU2	Full P05 P06 P07 P08	70	HT-C3501BPU-NE-PT2-F-CR1
	Fa Fb Fc Fd (4250-4750°K)	PT2 PU1 PU2	Full P05 P06 P07 P08	70	HT-C3501BPU-NF-PT2-F-CR1

Official Product	HT Part No. HT-C3501BPU	Your Part No.	Data Sheet No.
Tentative Product	*****	*****	Standard
Specifications are subject to changes for improvement without advance notice. Proprietary data, drawings, and company confidential all rights reserved.		July 08, 2011	Version of V1.2
			Page 17/35

## Color Temperature Coordinates

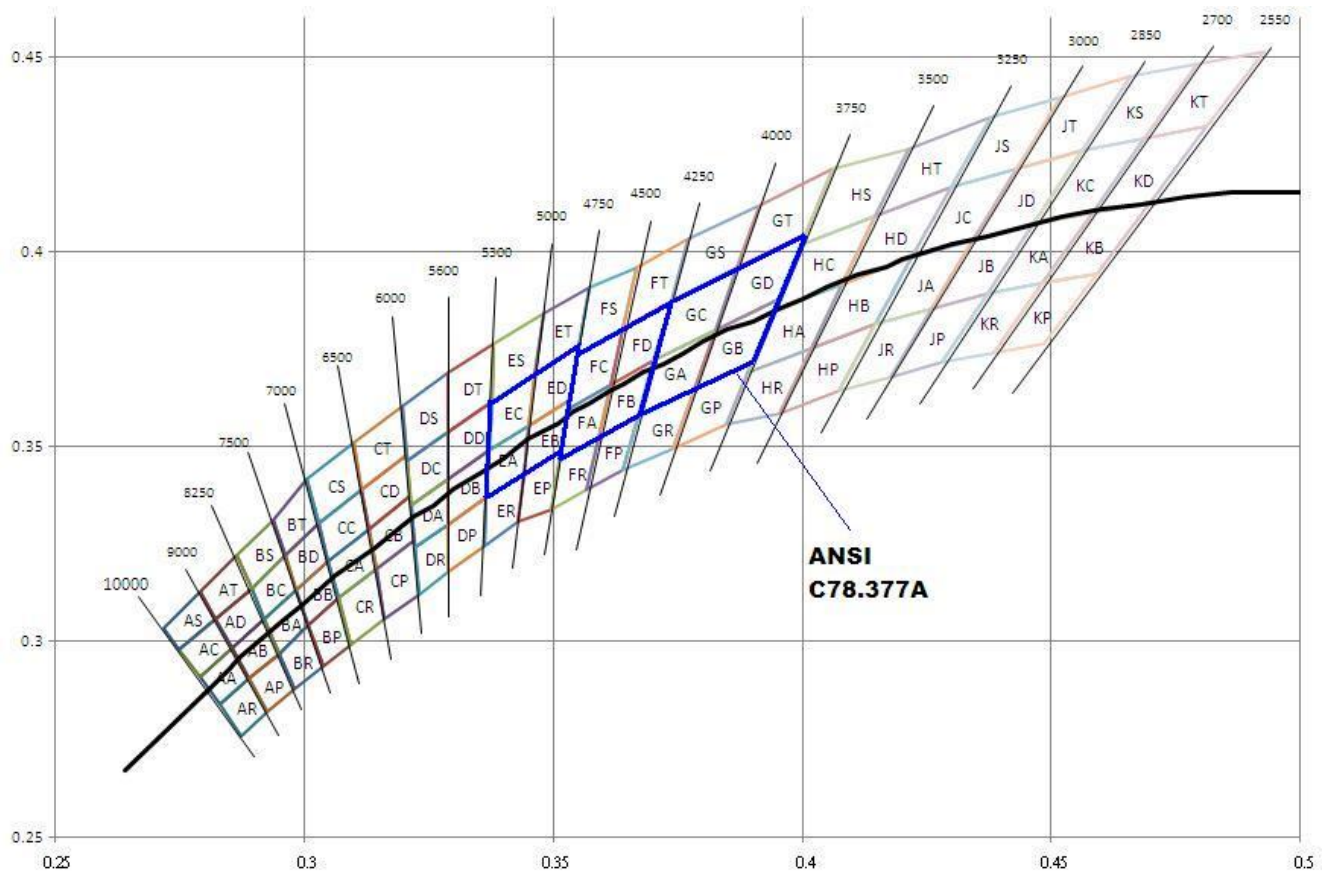

## Correlated Color Temperature Rank

Condition	Color	Bin Code	Min.	Typ.	Max.	Unit
$I_F=350\text{mA}$	Neutral White	GD	3750	-	4000	K
		GB	3750	-	4000	
		GC	4000	-	4250	
		GA	4000	-	4250	
		FD	4250	-	4500	
		FB	4250	-	4500	
		FC	4500	-	4750	
		FA	4500	-	4750	
		ED	4750	-	5000	
		EB	4750	-	5000	
		EC	5000	-	5300	
		EA	5000	-	5300	

Official Product	HT Part No. HT-C3501BPU	Your Part No.	Data Sheet No.
Tentative Product	*****	*****	Standard
Specifications are subject to changes for improvement without advance notice. Proprietary data, drawings, and company confidential all rights reserved.		July 08, 2011	Version of V1.2
			Page 18/35

## Luminous Flux Rank

Rank Code	Symbol	Condition	Min.	Typ.	Max.	Unit
Full	ΦV	IF=350mA	76.6	-	113.6	lm
PT2			76.6	-	87.4	
PU1			87.4	-	99.6	
PU2			99.6	-	113.6	

Note: It maintains a tolerance of  $\pm 10\%$  on flux

## Electrical Rank

Rank Code	Symbol	Condition	Min.	Typ.	Max.	Unit
Full	V <sub>F</sub>	I <sub>F</sub> =350mA	3.03	-	3.99	V
P05			3.03	-	3.27	
P06			3.27	-	3.51	
P07			3.51	-	3.75	
P08			3.75	-	3.99	

Note: It maintains a tolerance of  $\pm 0.1V$  on forward voltage measurements

Official Product	HT Part No. HT-C3501BPU	Your Part No.		Data Sheet No.
Tentative Product	*****	*****		Standard
Specifications are subject to changes for improvement without advance notice. Proprietary data, drawings, and company confidential all rights reserved.		July 08, 2011	Version of V1.2	Page 19/35

## Standard Order Codes and Bins (HT-C3501BPU Pure White)

The following tables of order codes list Correlated Color Temperature, Luminous Flux, Forward Voltage and CRI regions for the various categories of HT-C3501BPU. For other combinations, contact Harvatek or an authorized distributor.

HT-C3501BPU Standard Order Codes - Pure White					
Condition	Correlated Color Temperature	Luminous Flux	Forward Voltage	CRI	Order Code
I <sub>F</sub> =350mA	Ca Cb Cc Cd Da Db Dc Dd (5300-7000°K)	PU2 PV1 PV2	Full P05 P06 P07 P08	70	HT-C3501BPU-PW-PU2-F-CR1
	Da Db Dc Dd Ea Ec (5000-6000°K)	PU1 PU2 PV1 PV2	Full P05 P06 P07 P08	70	HT-C3501BPU-PDE-PU1-F-CR1
	Da Db Dc Dd (5500-6000°K)	PU1 PU2 PV1 PV2	Full P05 P06 P07 P08	70	HT-C3501BPU-PD-PU1-F-CR1

Official Product	HT Part No. HT-C3501BPU	Your Part No.		Data Sheet No.
Tentative Product	*****	*****		Standard
Specifications are subject to changes for improvement without advance notice. Proprietary data, drawings, and company confidential all rights reserved.		July 08, 2011	Version of V1.2	Page 20/35

## Color Temperature Coordinates

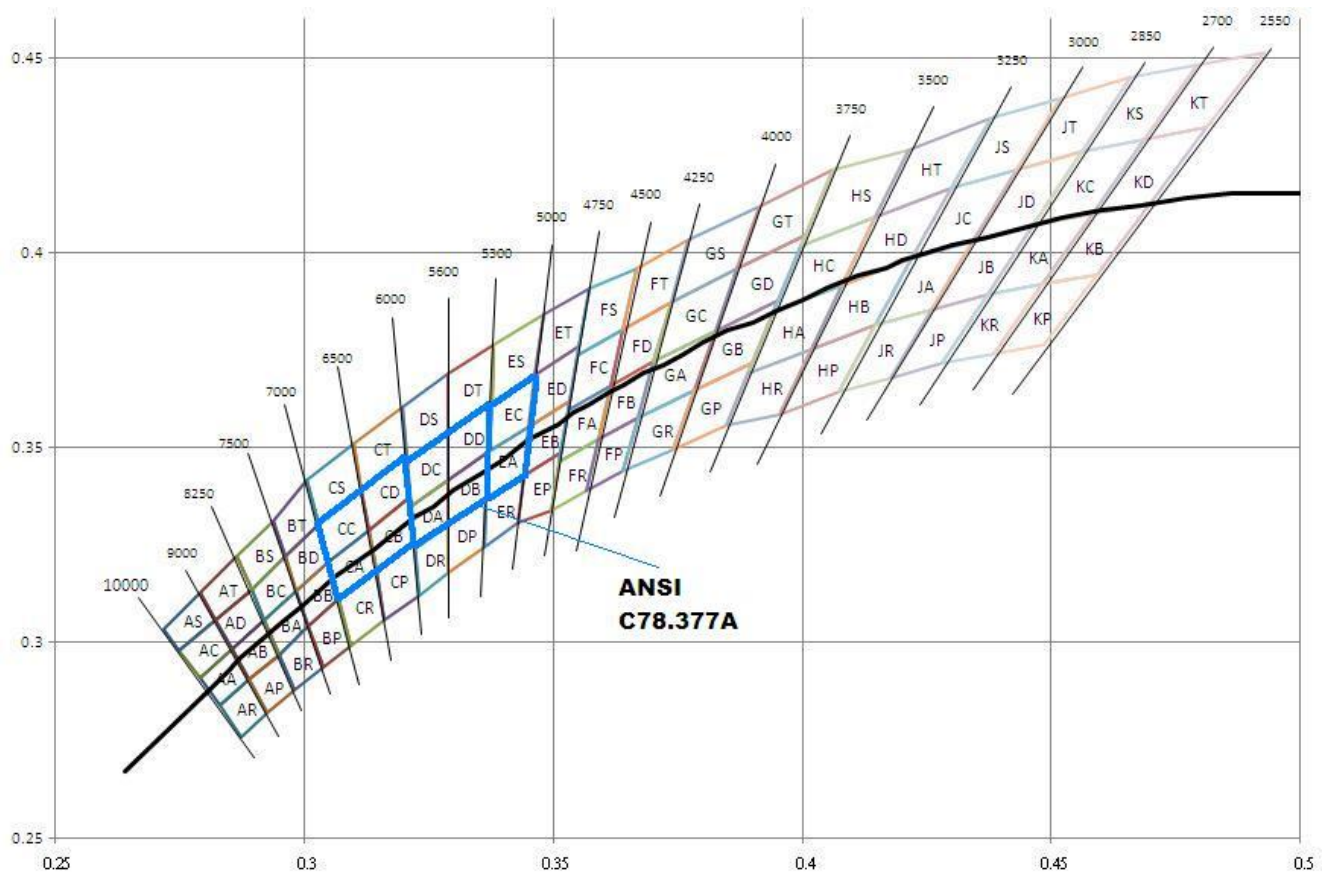

## Correlated Color Temperature Rank

Condition	Color	Bin Code	Min.	Typ.	Max.	Unit
I <sub>F</sub> =350mA	Pure White	EC	5000	-	5300	K
		EA	5000	-	5300	
		DD	5300	-	5600	
		DB	5300	-	5600	
		DC	5600	-	6000	
		DA	5600	-	6000	
		CD	6000	-	6500	
		CB	6000	-	6500	
		CC	6500	-	7000	
CA	6500	-	7000			

Official Product	HT Part No. HT-C3501BPU	Your Part No.	Data Sheet No.
Tentative Product	*****	*****	Standard
Specifications are subject to changes for improvement without advance notice. Proprietary data, drawings, and company confidential all rights reserved.		July 08, 2011	Version of V1.2
			Page 21/35

## Luminous Flux Rank

Rank Code	Symbol	Condition	Min.	Typ.	Max.	Unit
Full	ΦV	I <sub>F</sub> =350mA	87.4	-	147.2	lm
PU1			87.4	-	99.6	
PU2			99.6	-	113.6	
PV1			113.6	-	129.5	
PV2			129.5	-	147.2	

Note: It maintains a tolerance of ±10% on flux

## Electrical Rank

Rank Code	Symbol	Condition	Min.	Typ.	Max.	Unit
Full	V <sub>F</sub>	I <sub>F</sub> =350mA	3.03	-	3.99	V
P05			3.03	-	3.27	
P06			3.27	-	3.51	
P07			3.51	-	3.75	
P08			3.75	-	3.99	

Note: It maintains a tolerance of ±0.1V on forward voltage measurements

Official Product	HT Part No. HT-C3501BPU	Your Part No.		Data Sheet No.
Tentative Product	*****	*****		Standard
Specifications are subject to changes for improvement without advance notice. Proprietary data, drawings, and company confidential all rights reserved.		July 08, 2011	Version of V1.2	Page 22/35

## Standard Order Codes and Bins (HT-C3501BPU Cold White)

The following tables of order codes list Correlated Color Temperature, Luminous Flux, Forward Voltage and CRI regions for the various categories of HT-C3501BPU. For other combinations, contact Harvatek or an authorized distributor.

HT-C3501BPU Standard Order Codes - Cold White					
Condition	Correlated Color Temperature	Luminous Flux	Forward Voltage	CRI	Order Code
$I_F=350\text{mA}$	Aa Ab Ac Ad	PU1	Full	70	HT-C3501BPU-CW-PU1-F-CR1
	Ba Bb Bc Bd	PU2	P05		
	(7000-10000°K)	PV1	P06		
		PV2	P07		
			P08		

## Color Temperature Coordinates

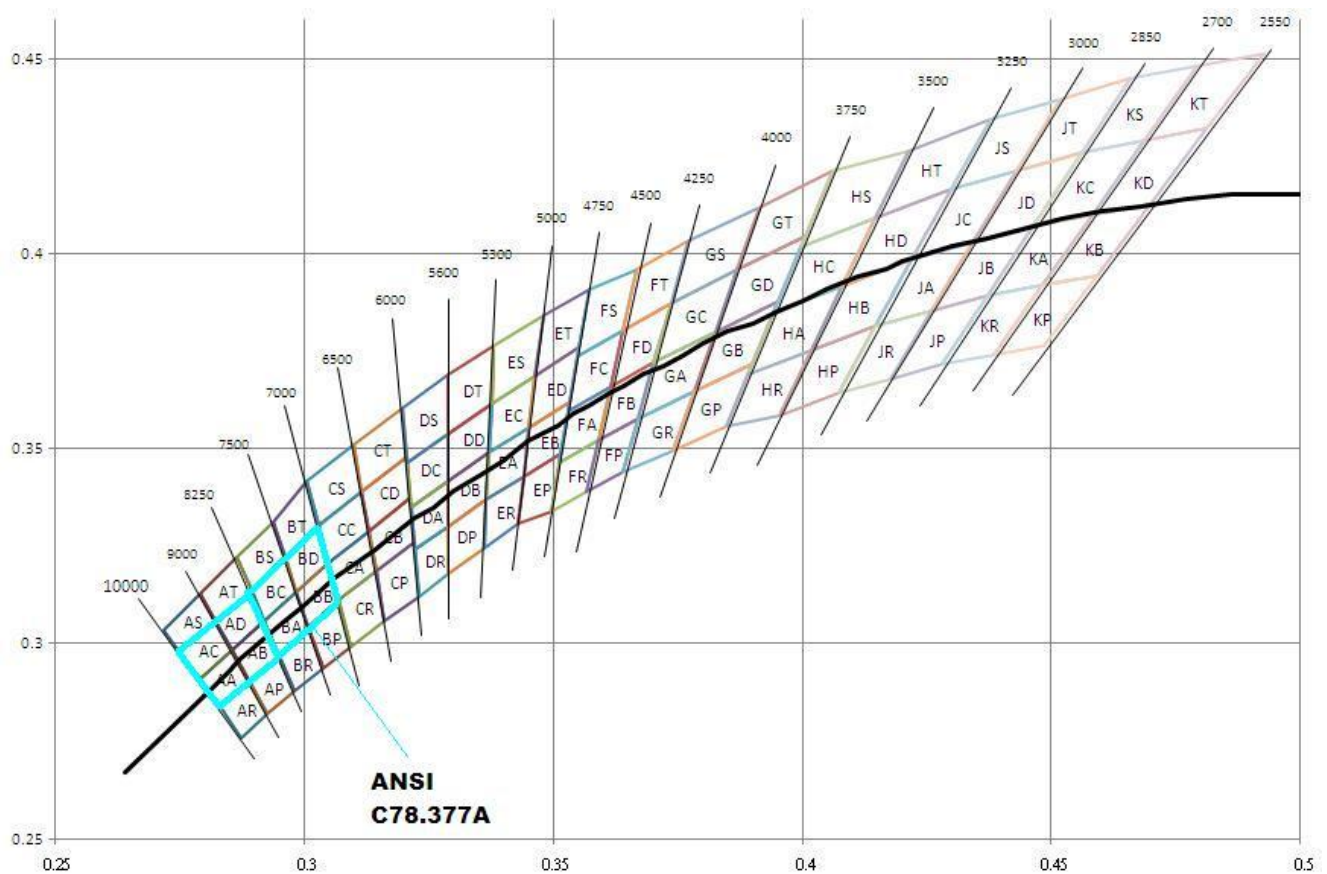

Official Product	HT Part No. HT-C3501BPU	Your Part No.	Data Sheet No.
Tentative Product	*****	*****	Standard
Specifications are subject to changes for improvement without advance notice. Proprietary data, drawings, and company confidential all rights reserved.		July 08, 2011	Version of V1.2
			Page 23/35

### Correlated Color Temperature Rank

Condition	Color	Bin Code	Min.	Typ.	Max.	Unit
I <sub>F</sub> =350mA	Cold white	BD	7000	-	7500	K
		BB	7000	-	7500	
		BC	7500	-	8250	
		BA	7500	-	8250	
		AD	8250	-	9000	
		AB	8250	-	9000	
		AC	9000	-	10000	
		AA	9000	-	10000	

### Luminous Flux Rank

Rank Code	Symbol	Condition	Min.	Typ.	Max.	Unit
Full	Φ <sub>V</sub>	I <sub>F</sub> =350mA	87.4	-	147.2	lm
PU1			87.4	-	99.6	
PU2			99.6	-	113.6	
PV1			113.6	-	129.5	
PV2			129.5	-	147.2	

Note: It maintains a tolerance of ±10% on flux

### Electrical Rank

Rank Code	Symbol	Condition	Min.	Typ.	Max.	Unit
Full	V <sub>F</sub>	I <sub>F</sub> =350mA	3.03	-	3.99	V
P05			3.03	-	3.27	
P06			3.27	-	3.51	
P07			3.51	-	3.75	
P08			3.75	-	3.99	

Note: It maintains a tolerance of ±0.1V on forward voltage measurements

Official Product	HT Part No. HT-C3501BPU	Your Part No.		Data Sheet No.
Tentative Product	*****	*****		Standard
Specifications are subject to changes for improvement without advance notice. Proprietary data, drawings, and company confidential all rights reserved.		July 08, 2011	Version of V1.2	Page 24/35

## Color Temperature Coordinates

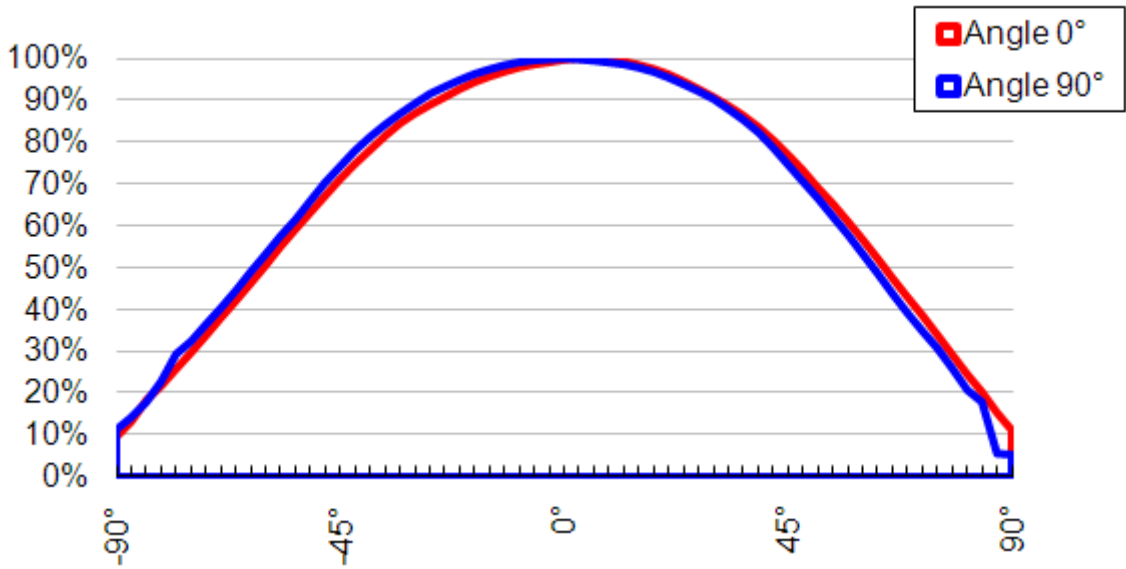
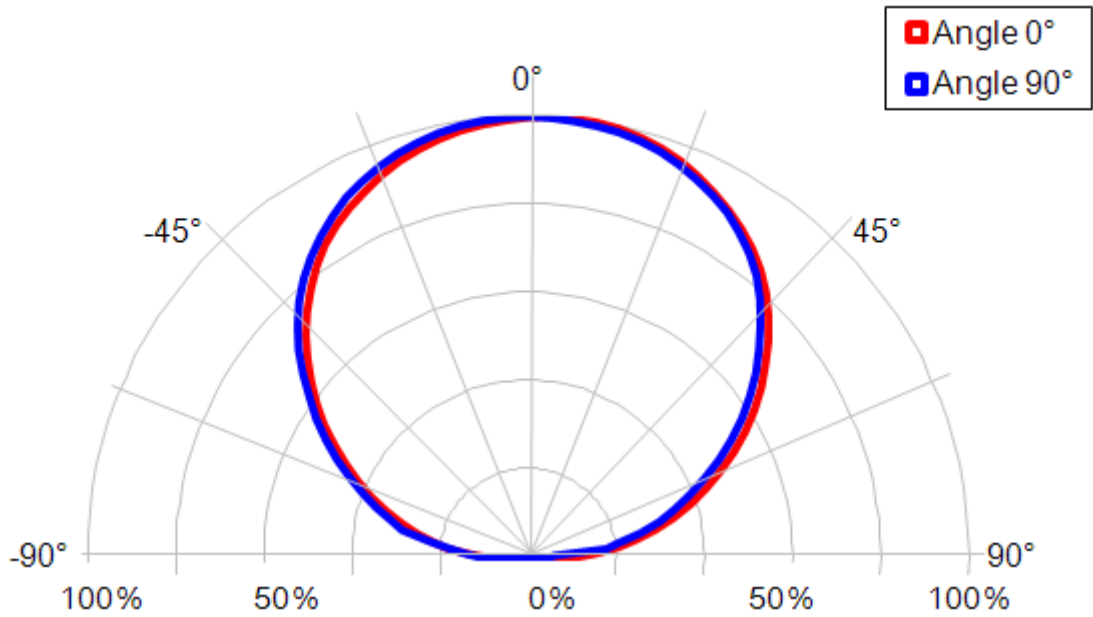

Official Product	HT Part No. HT-C3501BPU	Your Part No.		Data Sheet No.
Tentative Product	*****	*****		Standard
Specifications are subject to changes for improvement without advance notice. Proprietary data, drawings, and company confidential all rights reserved.		July 08, 2011	Version of V1.2	Page 25/35

## Characteristics Curve

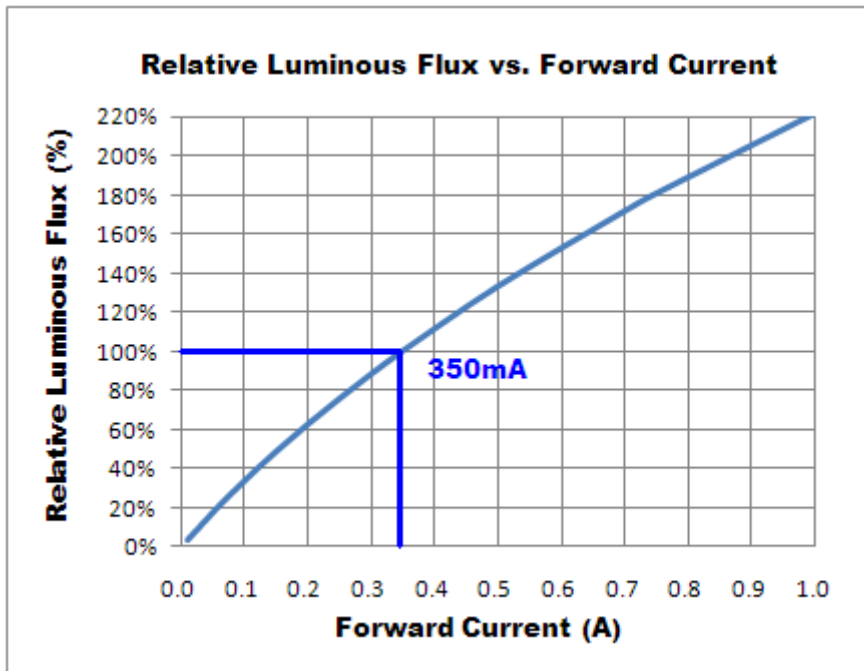
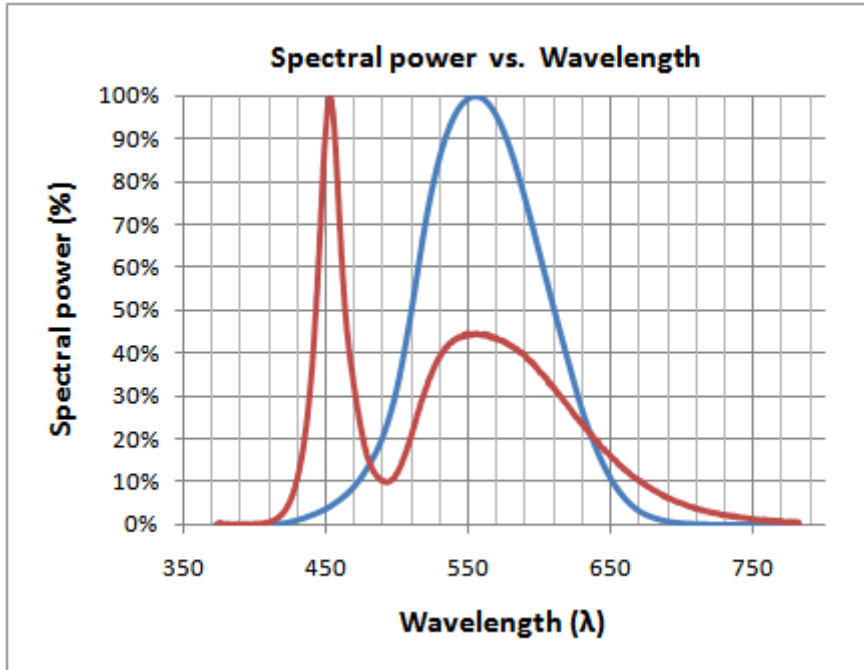

Official Product	HT Part No. HT-C3501BPU	Your Part No.	Data Sheet No.
Tentative Product	*****	*****	Standard
Specifications are subject to changes for improvement without advance notice. Proprietary data, drawings, and company confidential all rights reserved.		July 08, 2011	Version of V1.2
			Page 26/35

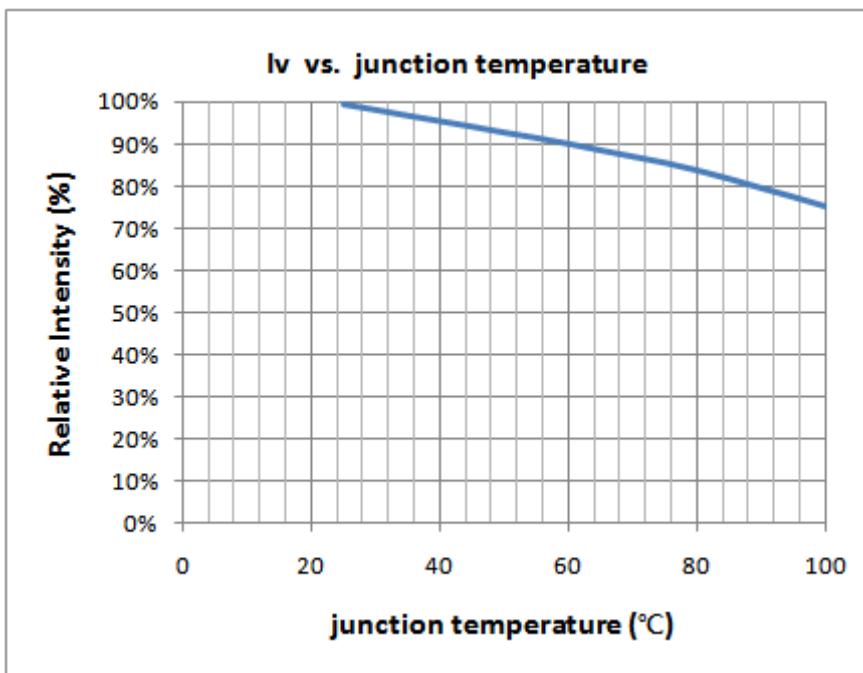
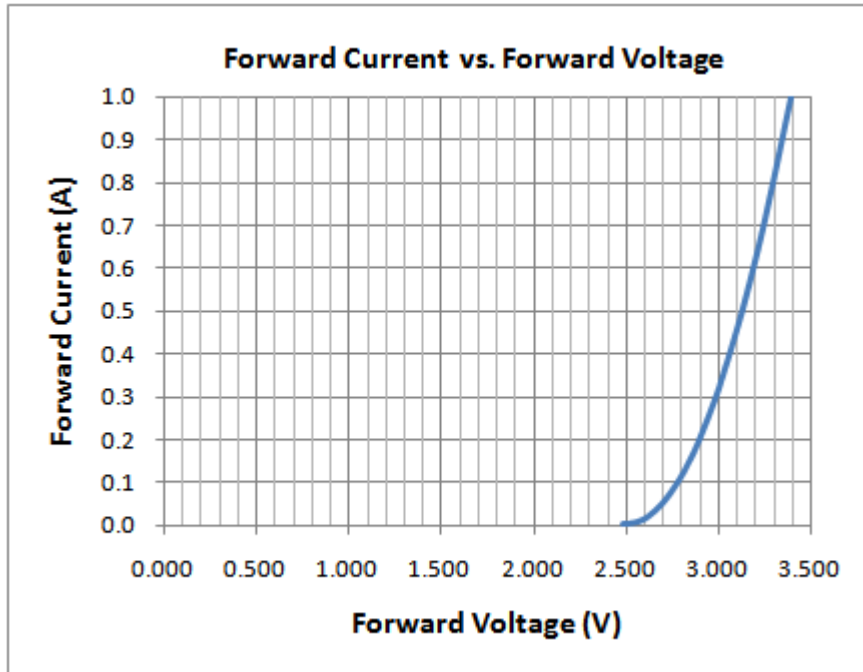

Official Product	HT Part No. HT-C3501BPU	Your Part No.	Data Sheet No.
Tentative Product	*****	*****	Standard
Specifications are subject to changes for improvement without advance notice. Proprietary data, drawings, and company confidential all rights reserved.		July 08, 2011	Version of V1.2
			Page 27/35

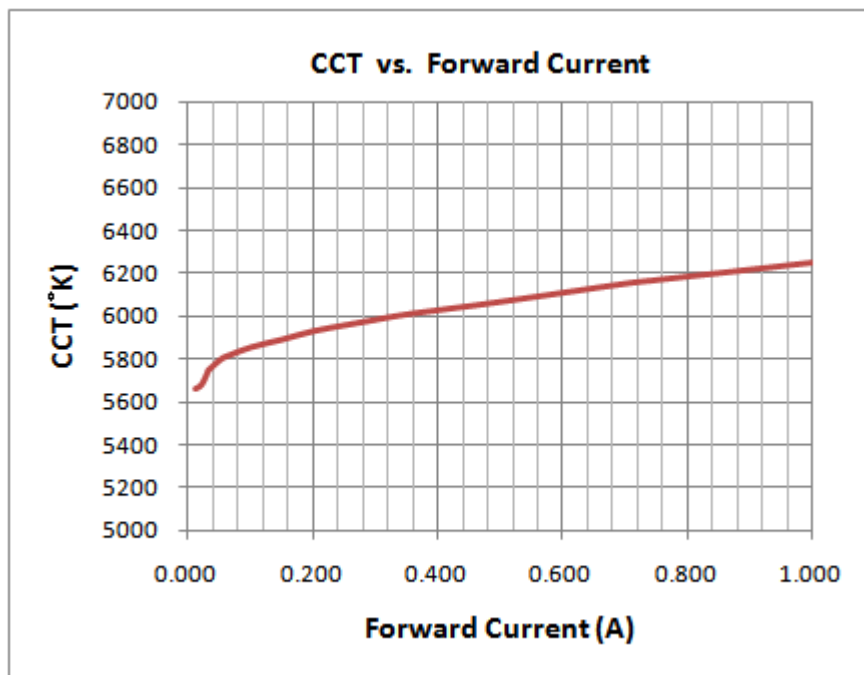
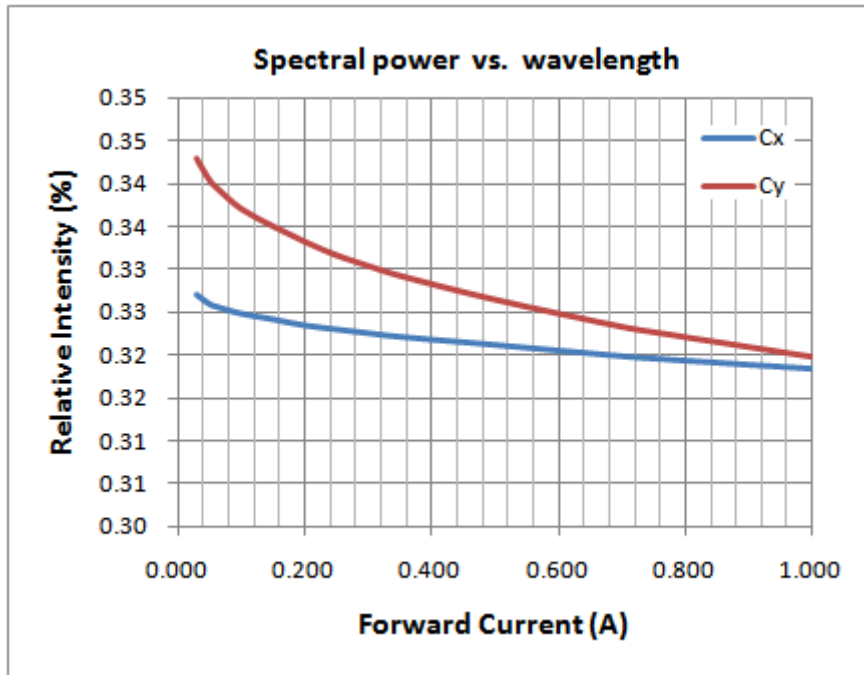

Official Product	HT Part No. HT-C3501BPU	Your Part No.	Data Sheet No.
Tentative Product	*****	*****	Standard
Specifications are subject to changes for improvement without advance notice. Proprietary data, drawings, and company confidential all rights reserved.		July 08, 2011	Version of V1.2
			Page 28/35

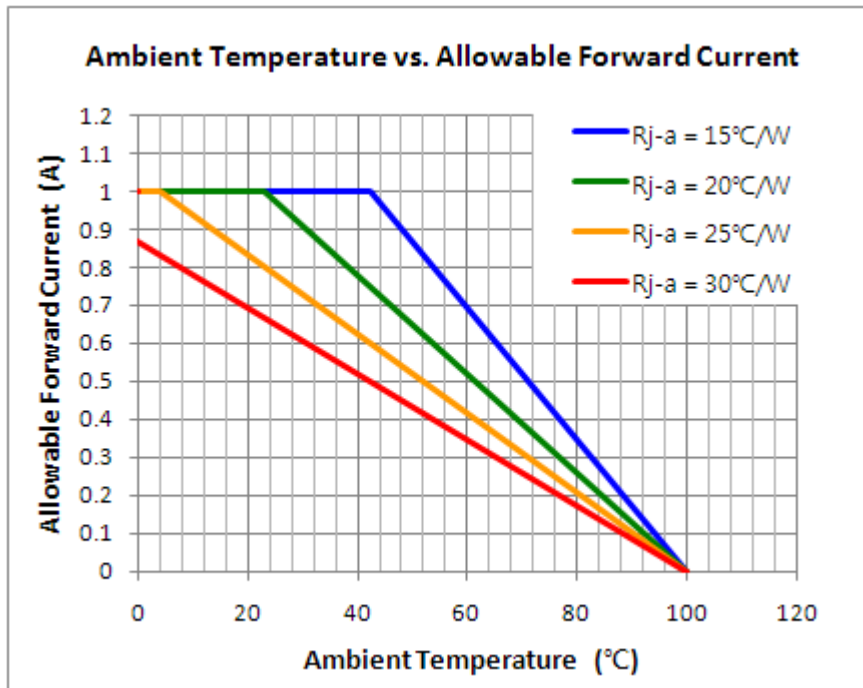
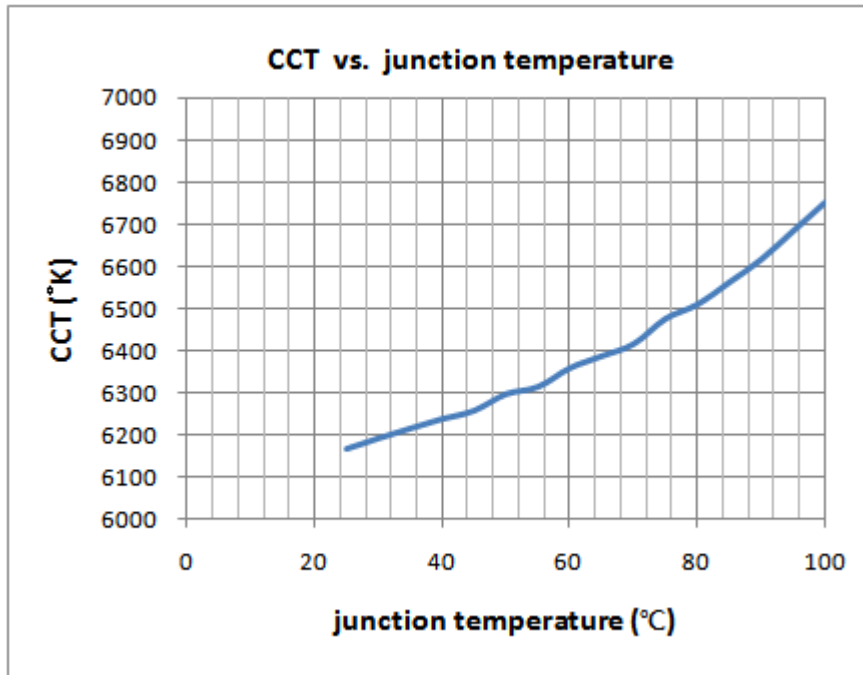

Official Product	HT Part No. HT-C3501BPU	Your Part No.	Data Sheet No.
Tentative Product	*****	*****	Standard
Specifications are subject to changes for improvement without advance notice. Proprietary data, drawings, and company confidential all rights reserved.		July 08, 2011	Version of V1.2
			Page 29/35

## Tape & Packing

### Tape Dimension

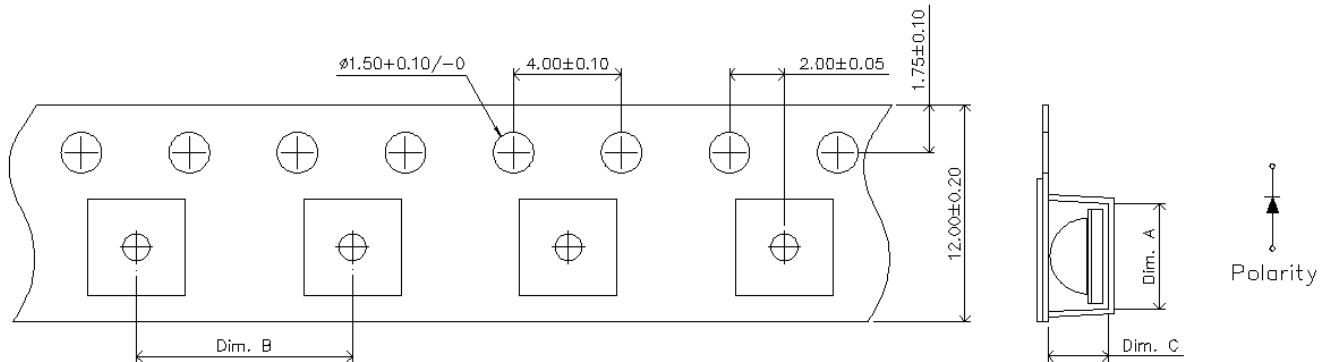

Part No.	Dim. A	Dim. B	Dim. C	Q'ty/Reel
HT-C3501	3.8	8.0	2.5	500

Unit: mm +/-0.1mm

### Reel Dimension

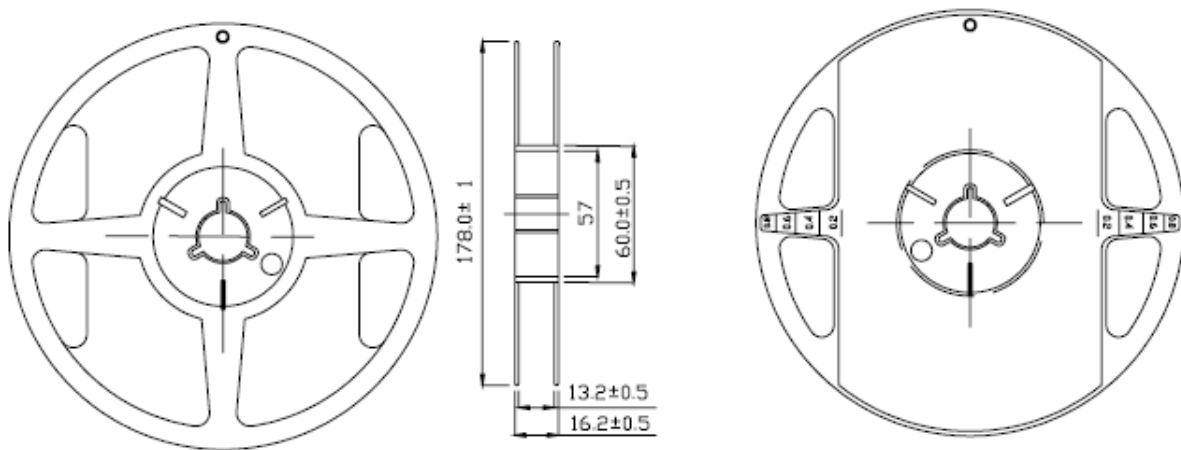

#### Notes:

1. All dimensions are in mm, tolerance is  $\pm 2.0$ mm unless otherwise noted.
2. Specifications are subject to change without notice.

Official Product	HT Part No. HT-C3501BPU	Your Part No.		Data Sheet No.
Tentative Product	*****	*****		Standard
Specifications are subject to changes for improvement without advance notice. Proprietary data, drawings, and company confidential all rights reserved.		July 08, 2011	Version of V1.2	Page 30/35

## Packing

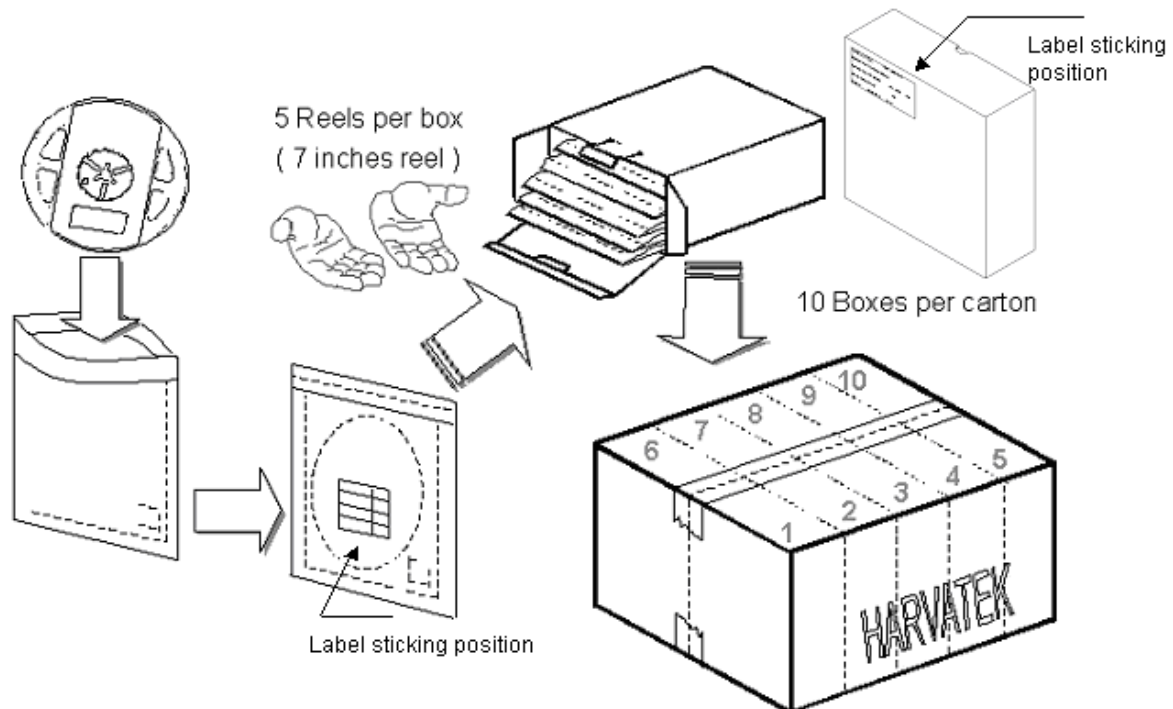

5 boxes per carton is available depending on shipment quantity.

## Dry Pack

All SMD optical devices are **MOISTURE SENSITIVE**. Avoid exposure to moisture at all times during transportation or storage. Every reel is packaged in a moisture protected anti-static bag. Each bag is properly sealed prior to shipment.

Upon request, a humidity indicator will be included in the moisture protected anti-static bag prior to shipment.

## Storage

It's recommended to store the products in the following conditions:

Humidity: 60 %RH Max.

Temperature: 5°C ~30°C (41°F~86°F)

Official Product	HT Part No. HT-C3501BPU	Your Part No.	Data Sheet No.
Tentative Product	*****	*****	Standard
Specifications are subject to changes for improvement without advance notice. Proprietary data, drawings, and company confidential all rights reserved.		July 08, 2011	Version of V1.2
			Page 31/35

The packaging sequence is as follows

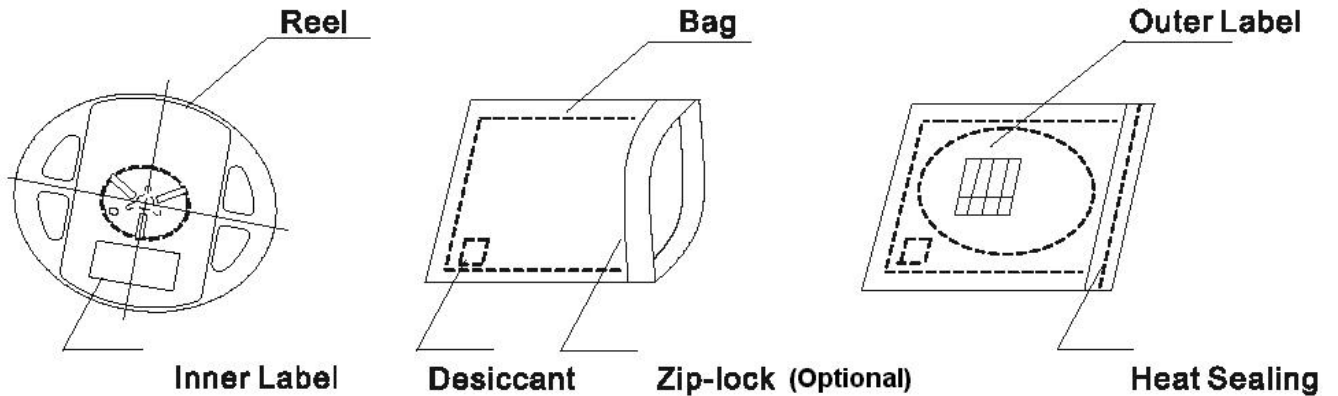

## PRECAUTIONS

1. Avoid exposure to moisture at all times during transportation or storage.
2. Anti-Static precaution must be taken when handling GaN, InGaN, and AlInGaP products.
3. It is suggested to connect the unit with a current limiting resistor of the proper size. Avoid applying a reverse voltage beyond the specified limit.
4. Avoid operation beyond the limits as specified by the absolute maximum ratings.
5. Avoid direct contact with the surface through which the LED emits light.
6. If possible, assemble the unit in a clean room or dust-free environment.

Official Product	HT Part No. HT-C3501BPU	Your Part No.	Data Sheet No.
Tentative Product	*****	*****	Standard
Specifications are subject to changes for improvement without advance notice. Proprietary data, drawings, and company confidential all rights reserved.		July 08, 2011	Version of V1.2
			Page 32/35

## Soldering Pattern

The dimensions of the recommended soldering pattern may not meet every user. Please confirm and study first before designing the soldering pattern in order to obtain the best performance of soldering. Recommended soldering pattern is listed below:

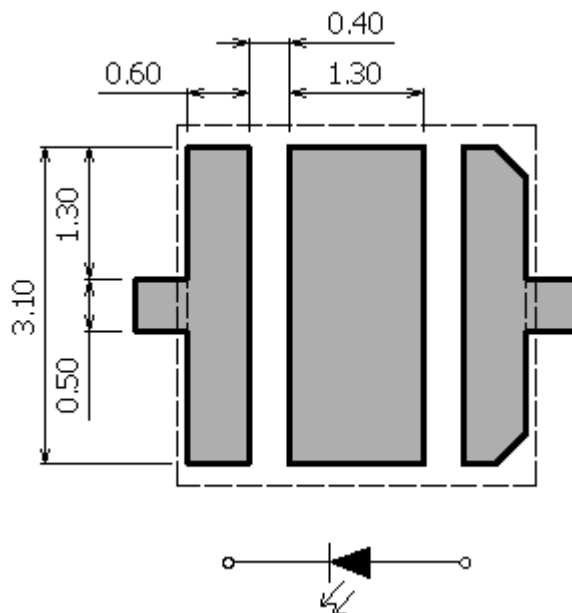

Unit: mm

## Reflow Soldering

Recommend soldering paste specifications:

1. Operating temp.: Above 220 °C ,60sec
2. Peak temp.:260 °CMax.,10sec Max.
3. Never take next process until the component is cooled down to room temperature after reflow.
4. The recommended reflow soldering profile (measuring on the surface of the LED terminal) is following:

Lead-free Solder Profile

Official Product	HT Part No. HT-C3501BPU	Your Part No.		Data Sheet No.
Tentative Product	*****	*****		Standard
Specifications are subject to changes for improvement without advance notice. Proprietary data, drawings, and company confidential all rights reserved.		July 08, 2011	Version of V1.2	Page 33/35

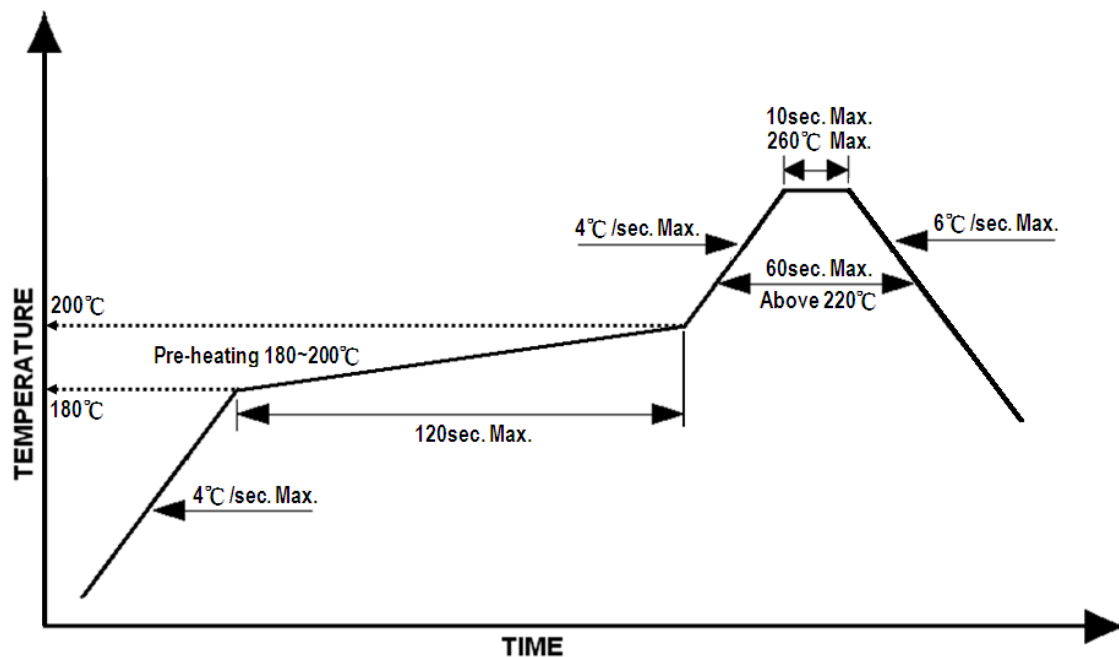

## Cleaning

Following are cleaning procedures after soldering:

- An alcohol-based solvent such as isopropyl alcohol (IPA) is recommended.
- Temperature x Time should be 50°C x 30sec. or <30°C x 3min
- Ultra sonic cleaning: < 15W/ bath; bath volume ≤ 1liter
- Curing: 100 °C max, <3min
- 

## Cautions of Pick and Place

- Avoid stress on the resin at elevated temperature.
- Avoid rubbing or scraping the resin by any object.
- Electric-static may cause damage to the component. Please ensure that the equipment is properly grounded. Use of an ionizer fan is recommended.

## LEDs and Eye Safety:

In the 1993 edition of IEC-60825-1, LEDs were included: "Throughout this part 1 light emitting diodes (LED) are included whenever the word "laser" is used."The CENELEC document EN 60825-1 contains all the technical content of the IEC standard.

The scope of the IEC standard states that "...products which are sold to other manufacturers for use as components of any system for subsequent sale are not subject to IEC 60825-1, since the final product will itself be subject to this standard. "Therefore, it is important to determine the Laser Safety Class of the final product. However, it is important that employees working with LEDs are trained to use them safely.

Most of the products containing LEDs will fall in either Class 1 or Class 2. A Class 1 label is optional:

Official Product	HT Part No. HT-C3501BPU	Your Part No.	Data Sheet No.
Tentative Product	*****	*****	Standard
Specifications are subject to changes for improvement without advance notice. Proprietary data, drawings, and company confidential all rights reserved.		July 08, 2011	Version of V1.2
			Page 34/35

## CLASS 1 LED PRODUCT

If a label is not used, this description must be included in the information for the user. Amendment 2 to IEC 60825-1 is expected to be published in January 2001. The CENELEC equivalent is expected to follow three months after the IEC publication. This document contains increased Class 1 and Class 2 limits, as well as the introduction of less restrictive Class 1M and Class 2M.

For the exact classification and further information, the IEC document can be used:

IEC-60825-1 ISBN 2-8318-4169-0

Official Product	HT Part No. HT-C3501BPU	Your Part No.		Data Sheet No.
Tentative Product	*****	*****		Standard
Specifications are subject to changes for improvement without advance notice. Proprietary data, drawings, and company confidential all rights reserved.		July 08, 2011	Version of V1.2	Page 35/35