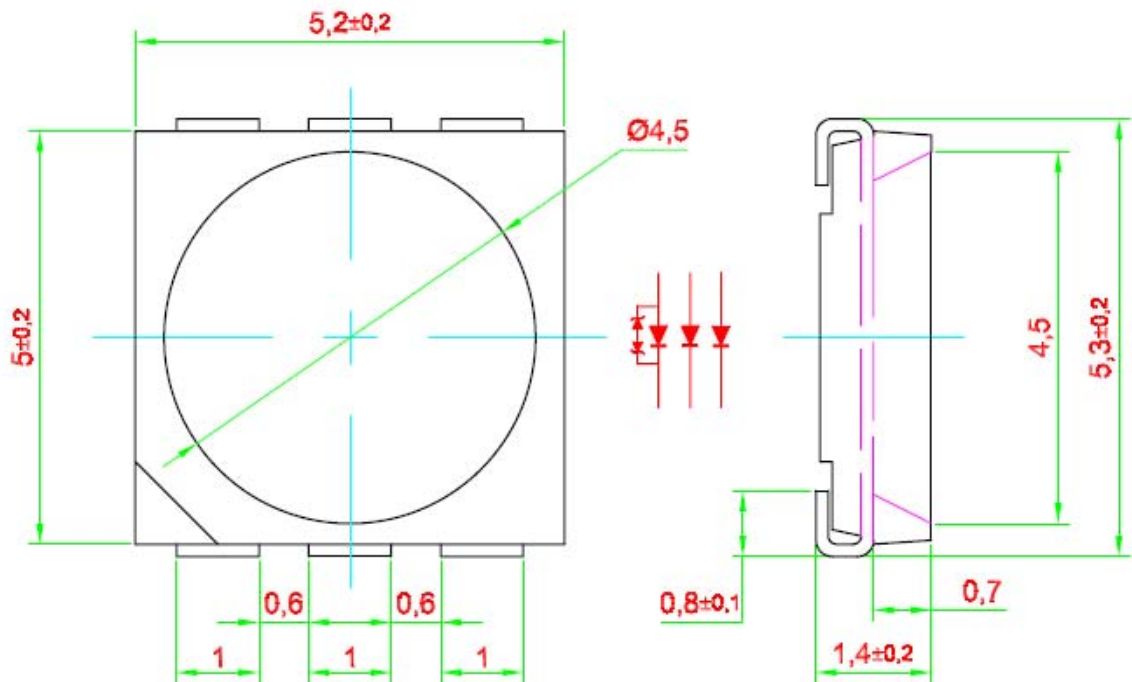

Engineering reference data are not verified. The specifications are subject to change without notice.

Maxi DomiLED White: DBWW-DJG

- Super high brightness surface mount LED.
- Large light emitting window of 4.5mm diameter.
- 120° viewing angle.
- Compact package outline (LxW) of 5.3 x 5.2 x 1.4 mm.
- Compatible to IR reflow soldering.

Engineering reference data are not verified. The specifications are subject to change without notice.

Material

	Material
Lead-frame.	Cu Alloy With Ag Plating.
Package.	High Temperature Resistant Plastic, PPA.
Encapsulant	Silicone Resin.
Soldering Leads.	Sn Plating.

Note: This product is Pb free.

Absolute Maximum Ratings

	Maximum Value	Unit
DC forward current. ^{*1}	20	mA
Peak pulse current. ^{*1} ($t_p \leq 10 \mu s$, Duty cycle = 0.1)	100	mA
Reverse voltage. ^{*1}	Not designed for reverse bias	V
LED junction temperature. ^{*1}	125	°C
Operating temperature.	-40 ... +100	°C
Storage temperature.	-40 ... +100	°C
ESD Threshold (HBM)	1000	V

*1 Rating is based on individual chip.

Engineering reference data are not verified. The specifications are subject to change without notice.

Optical Characteristics at Tj=25°C.

Part Number	Intensity @ If=20mA (mcd) / chip			Viewing Angle
	Min	Typ.	Max	
DBWWW-DJG-Z4Z5-R	5,000	6,000	7,000	120

IV Bin	Intensity @ If = 20mA (mcd)	
	Min	Max
Z4	5,000	6,000
Z5	6,000	7,000

1. Luminous intensity is measured with an accuracy of ±11%.
2. Wavelength binning is carried for all units as per the wavelength-binning table. Only one wavelength group is allowed for each reel.

Electrical Characteristics at Tj=25°C.

Part Number	Vf @ If = 20mA		
	Min. (V)	Typ. (V)	Max.(V)
DBWWW-DJG	2.9	3.2	3.5

Forward voltages are tested using a current pulse of 1 ms and has an accuracy of ± 0.1V.

Vf Binning

Vf Bin @ 20mA	Forward voltage (V)
V1	2.90 ... 3.00
V2	3.00 ... 3.10
V3	3.10 ... 3.20
V4	3.20 ... 3.30
V5	3.30 ... 3.40
V6	3.40 ... 3.50

Forward voltage, Vf is measured with an accuracy of ±0.1 V.

Engineering reference data are not verified. The specifications are subject to change without notice.

Color Bin

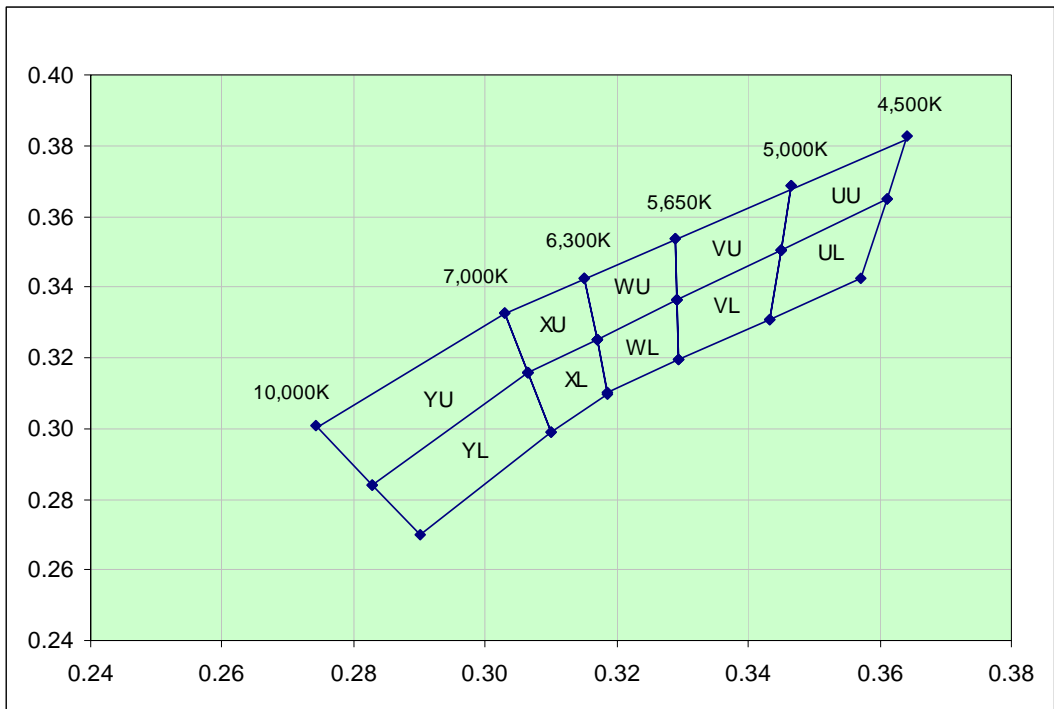

Chromaticity coordinate groups are measured with an accuracy of ± 0.01 .

Bin		1	2	3	4
YU	Cx	0.274	0.283	0.307	0.303
	Cy	0.301	0.284	0.316	0.333
YL	Cx	0.283	0.290	0.310	0.307
	Cy	0.284	0.270	0.299	0.316
XU	Cx	0.303	0.307	0.317	0.315
	Cy	0.333	0.316	0.325	0.343
XL	Cx	0.307	0.310	0.319	0.317
	Cy	0.316	0.299	0.310	0.325
WU	Cx	0.315	0.317	0.329	0.329
	Cy	0.343	0.325	0.336	0.354
WL	Cx	0.317	0.319	0.329	0.329
	Cy	0.325	0.310	0.319	0.336
VU	Cx	0.329	0.329	0.345	0.347
	Cy	0.354	0.336	0.350	0.368
VL	Cx	0.329	0.329	0.343	0.345
	Cy	0.336	0.319	0.331	0.350
UU	Cx	0.347	0.345	0.361	0.364
	Cy	0.368	0.350	0.365	0.383
UL	Cx	0.345	0.343	0.357	0.361
	Cy	0.350	0.331	0.343	0.365

Engineering reference data are not verified. The specifications are subject to change without notice.

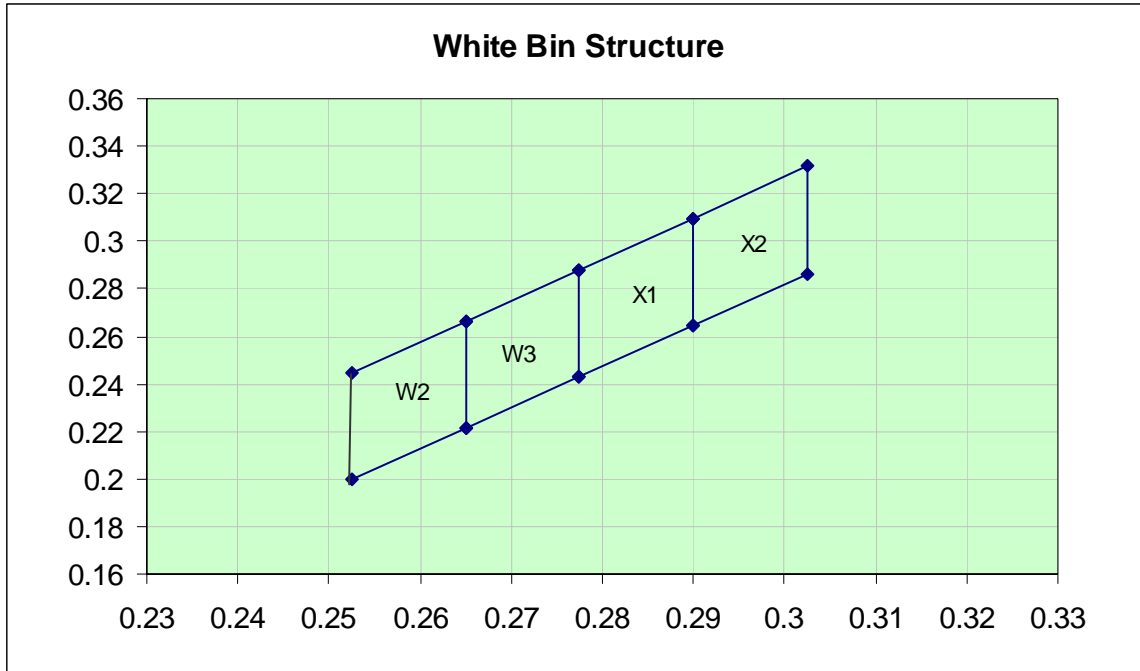

Chromaticity coordinate groups are measured with an accuracy of ± 0.01 .

W2	0.2525	0.2650	0.2650	0.2525
	0.1998	0.2215	0.2665	0.2448
W3	0.2650	0.2775	0.2775	0.2650
	0.2215	0.2431	0.2881	0.2665
X1	0.2775	0.2900	0.2900	0.2775
	0.2431	0.2648	0.3098	0.2881
X2	0.2900	0.3025	0.3025	0.2900
	0.2648	0.2864	0.3314	0.3098

Engineering reference data are not verified. The specifications are subject to change without notice.

Solder Pad Design.

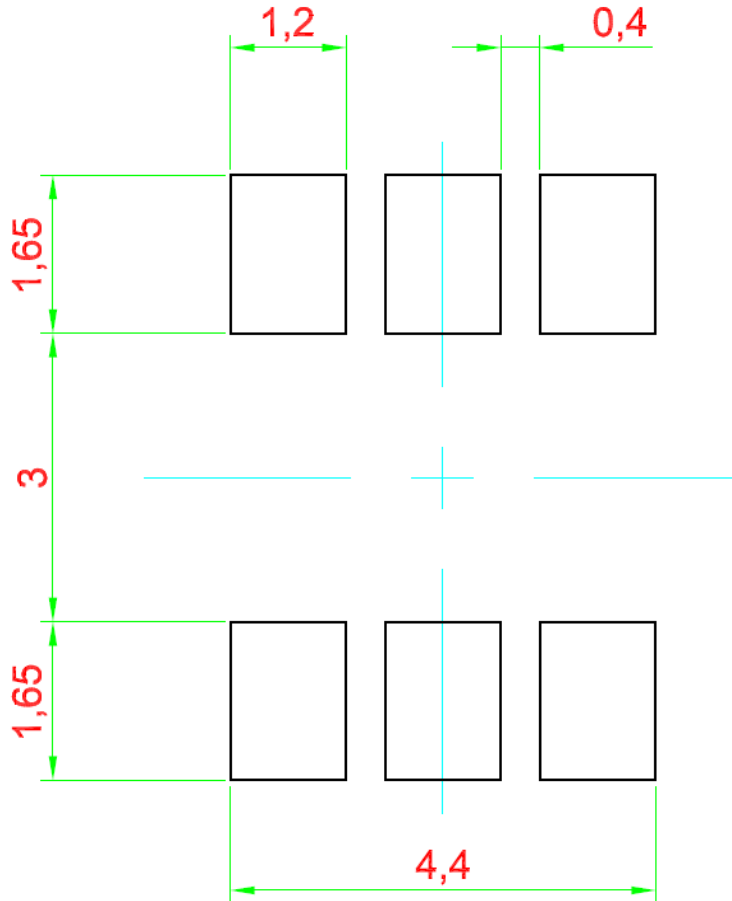

Engineering reference data are not verified. The specifications are subject to change without notice.

Relative intensity vs. forward current

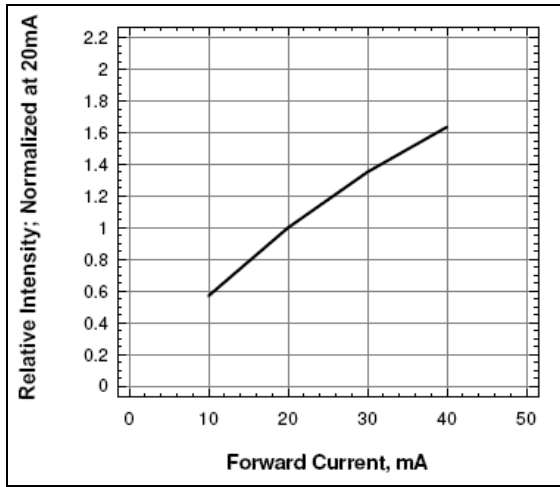

Forward voltage vs. forward current

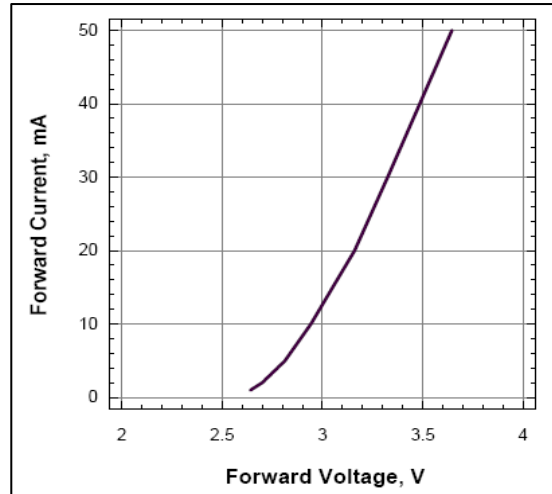

Radiation pattern.

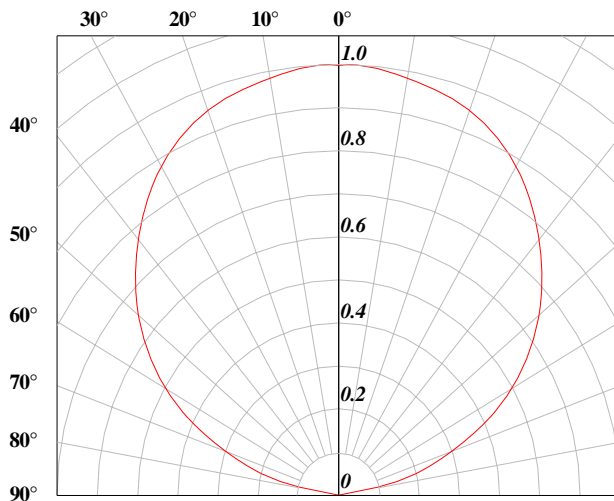

Color Spectrum

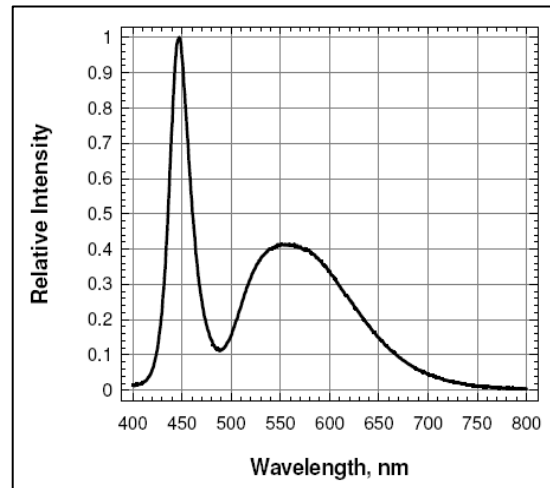

Maximum forward current vs. temperature

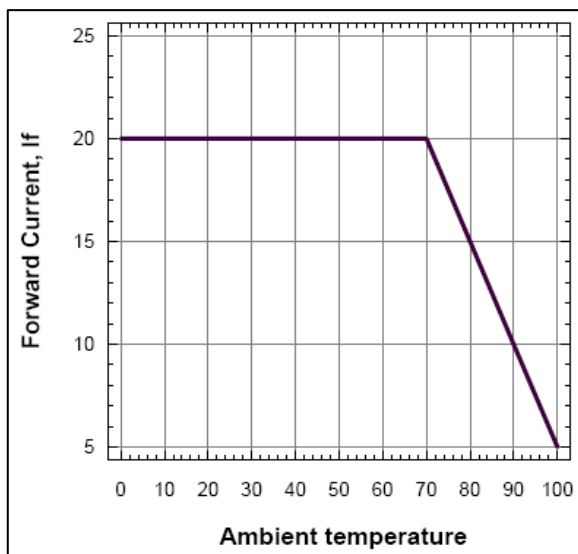

Engineering reference data are not verified. The specifications are subject to change without notice.

Taping And Orientation.

Reels come in quantity of 1000 units.

Reel diameters are 180 mm.

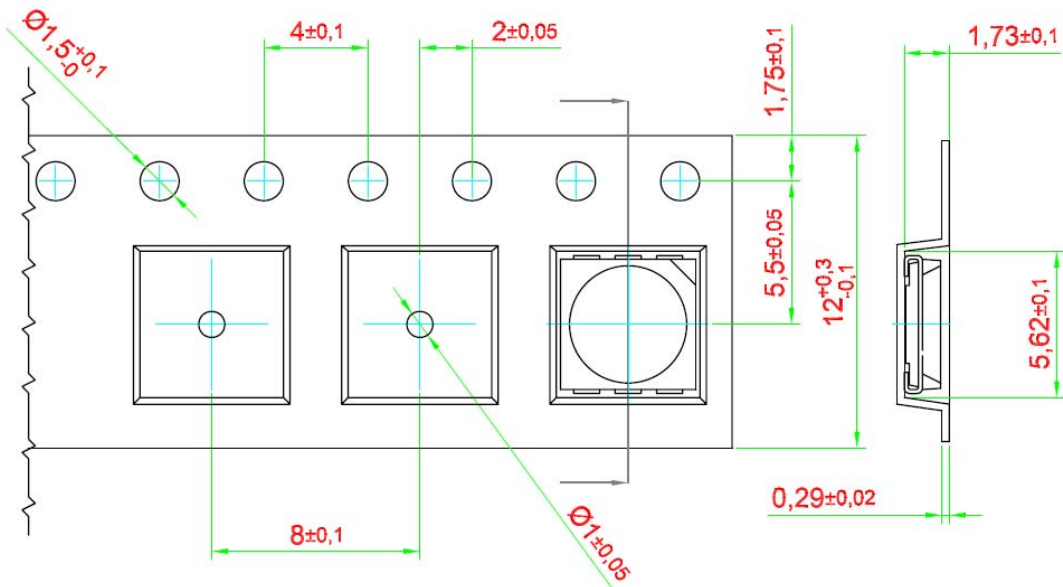

Engineering reference data are not verified. The specifications are subject to change without notice.

Recommended Sn-Pb IR-Reflow Soldering Profile.

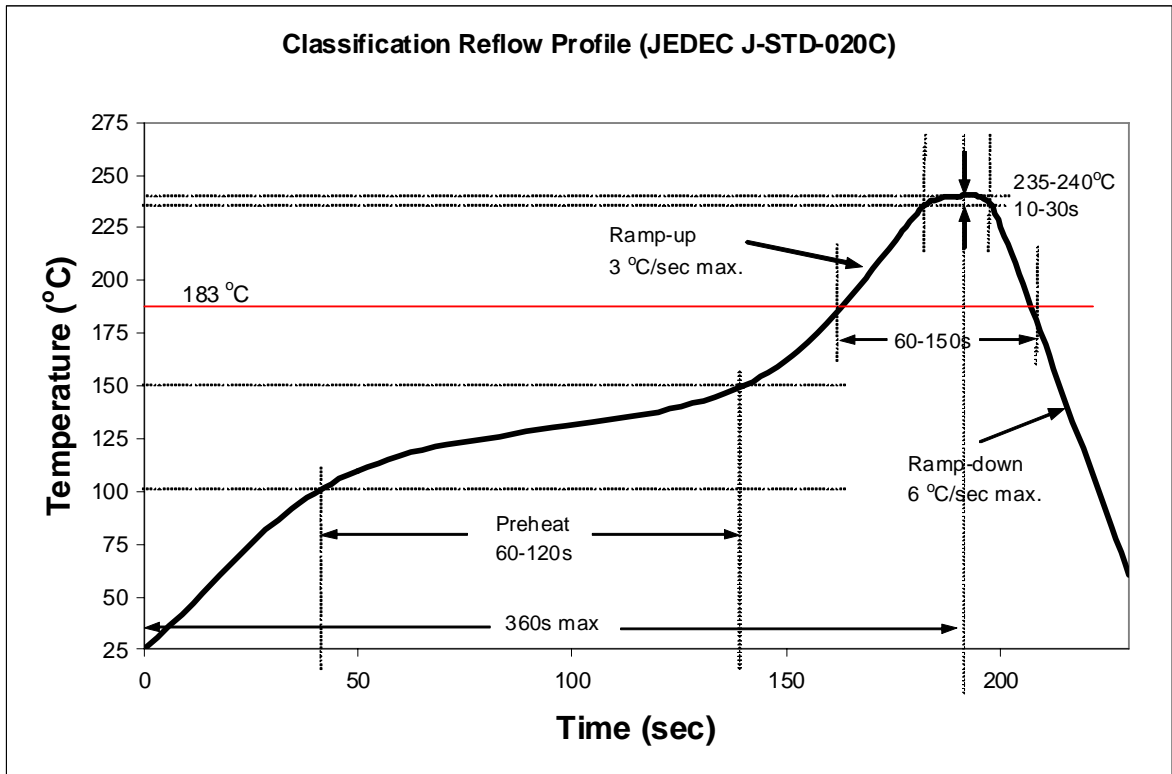

Recommended Pb Free IR-Reflow Soldering Profile.

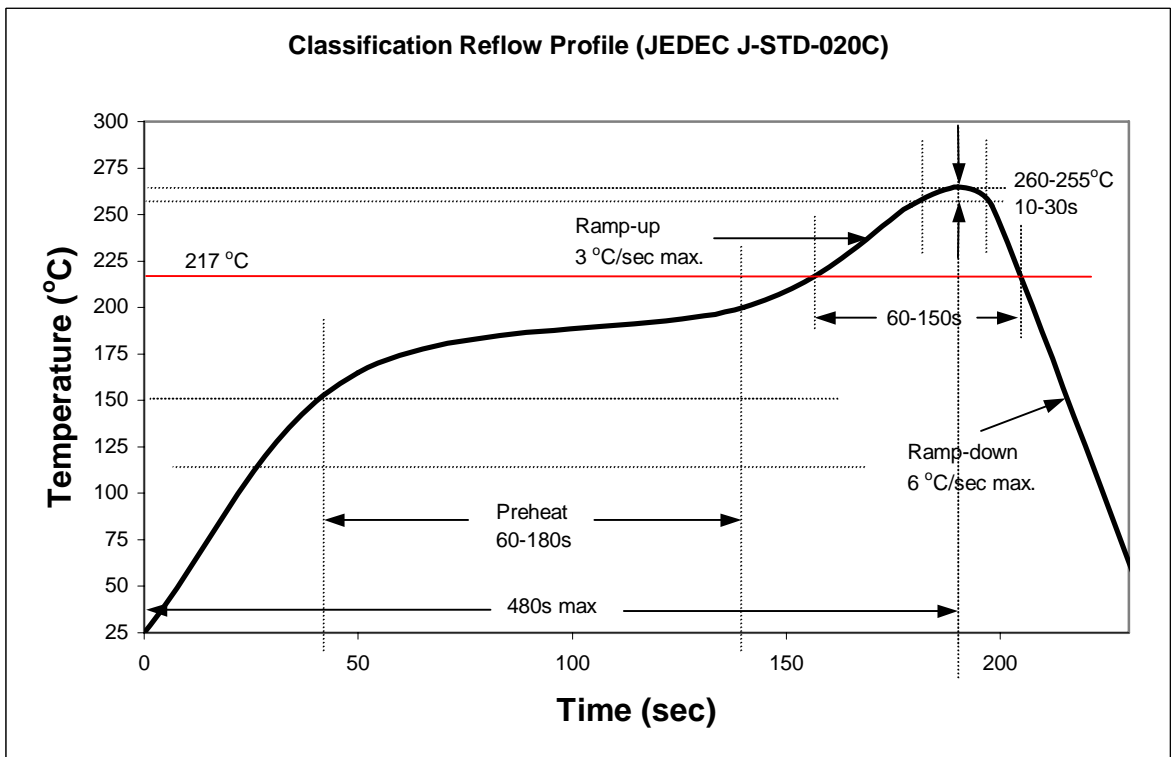

Engineering reference data are not verified. The specifications are subject to change without notice.

NOTE.

All the information published is considered to be reliable. However, DOMINANT Semiconductors does not assume any liability arising out of the application or use of any product described herein.

DOMINANT Semiconductors reserves the right to make changes at any time without notice to any products in order to improve reliability, function or design.

DOMINANT Semiconductors products are not authorized for use as critical components in life support devices or systems without the express written approval from the managing director of DOMINANT Semiconductors.